

TRSL-8380G

(RoHS Compliant)

3.3V / 1550 nm / 4.25 Gbps SFF LC SINGLE-MODE TRANSCEIVER

FEATURES

- Up to 4.25 Gb/s Bi-directional Data Links
- Duplex LC Single Mode Transceiver
- Fibre Channel FC-PI 400/200/100-SM-LC-L Compliant
- IEEE 802.3z 1000BASE-LX Compliant
- Small Form-Factor, RJ-45 size, 2x5 pin Package
- 1550 nm DFB LD Transmitter
- High Sensitivity APD Receiver
- Up to 80 km at 4.25 Gb/s
- AC/AC Coupled Signal Input / Output
- LVTTL Transmitter Disable Input
- LVTTL Signal Detect Output
- Single +3.3 V Power Supply
- **RoHS Compliant**
- 0 to 70°C Operating
- Wave Solderable
- Class 1 Laser International Safety Standard IEC-60825 Compliant

APPLICATIONS

- Tri-Rate 1.063/2.125/4.25 Gb/s Fibre Channel
- 1.25 Gb/s 1000BASE-LX Gigabit Ethernet

DESCRIPTION

The TRSL-8380G series single mode transceiver is a small form factor, low power, high performance module for bi-directional serial optical data communications such as 4x/2x/1x Fibre Channel and 1000BASE-LX Gigabit Ethernet. This module is designed for single mode fiber and operates at a nominal wavelength of 1550 nm. The transmitter section uses a multiple quantum well 1550 nm DFB laser and is a class 1 laser compliant according to International Safety Standard IEC-60825. The receiver section uses an integrated InGaAs detector preamplifier (IDP) mounted in an optical header and a limiting post-amplifier IC. A LVPECL logic interface simplifies interface to external circuitry.

LASER SAFETY

This single mode transceiver is a Class 1 laser product. It complies with IEC-60825 and FDA 21 CFR 1040.10 and 1040.11. The transceiver must be operated within the specified temperature and voltage limits. The optical ports of the module shall be terminated with an optical connector or with a dust plug.

ORDER INFORMATION

P/No.	Bit Rate (Gb/s)	FC-PI	Distance (km)	Wavelength (nm)	Package	Temp. (°C)	TX Power (dBm)	RX Sens. (dBm)	RoHS Compliant
TRSL-8380G	4 / 2 / 1	400/200/100	80	1550 DFB	2x5 LC	0 to 70	4 to 0	-26	Yes

Absolute Maximum Ratings

Parameter	Symbol	Min	Max	Units	Notes
Storage Temperature	Tstg	-40	85	°C	
Operating Temperature	Topr	0	70	°C	
Soldering Temperature	---		260	°C	10 seconds on leads only
Power Supply Voltage	Vcc	0	4.5	V	
Input Voltage	---	GND	Vcc	V	
Output Current	Iout	0	30	mA	

Recommended Operating Conditions

Parameter	Symbol	Min	Typ	Max	Units / Notes
Power Supply Voltage	Vcc	3.13	3.3	3.47	V
Operating Temperature	Topr	0		70	°C / air flow 1m/sec
Data Rate		1	4.25		Gb/s
Power Supply Current	Icc		200	300	mA

Transmitter Specifications (0°C < Topr < 70°C, 3.13V < Vcc < 3.47V)						
Parameter	Symbol	Min	Typ	Max	Units	Notes
Optical						
Optical Transmit Power	Po	0	---	4	dBm	1
Optical Modulation Amplitude@4.25Gb/s	OMA	1200			μW	
Output Center Wavelength	λ	1480		1580	nm	
Output Spectrum Width	Δλ	---		1	nm	-20 dB width
Side Mode Suppression Ratio	SMSR	30			dB	
Optical Rise / Fall Time (4.25Gb/s)	tr / tf			90	ps	20% to 80% Values
Relative Intensity Noise	RIN			-118	dB/Hz	
Electrical						
Data Input Current – Low	I _{IL}	-350			μA	
Data Input Current – High	I _{IH}			350	μA	
Differential Input Voltage	V _{IH} - V _{IL}	300			mV	
Data Input Voltage – Low	V _{IL} - V _{CC}	-2.0		-1.58	V	2
Data Input Voltage – High	V _{IH} - V _{CC}	-1.1		-0.74	V	2
Disable Input Voltage – Low	V _{TDIS,L}	0		0.5	V	TX Output Enabled
Disable Input Voltage – High	V _{TDIS,H}	V _{CC} -1.3		V _{CC}	V	TX Output Disabled
Shut Off Time for TxDis	T _{DIS}			1	ms	

1. Output power is power coupled into a 9/125 μm single mode fiber.
2. These inputs are compatible with 10K, 10KH and 100K ECL and PECL inputs.

Receiver Specifications (0°C < Topr < 70°C, 3.13V < Vcc < 3.47V)						
Parameter	Symbol	Min	Typ	Max	Units	Notes
Optical						
Sensitivity@4.25Gb/s	Sen1	---	---	3.2	μW	3
				-26	dBm	4
Maximum Input Power	Pin	-9			dBm	
Signal Detect – Asserted	Pa	---	---	-26	dBm	Transition: low to high
Signal Detect – Deasserted	Pd	-40	---	---	dBm	Transition: high to low
Signal detect – Hysteresis		1.0	---		dB	
Wavelength of Operation		1260	---	1600	nm	
Electrical						
Data Output Voltage – Low	V _{OL} - V _{CC}	-2.0		-1.58	V	5
Data Output Voltage – High	V _{OH} - V _{CC}	-1.1		-0.74	V	5
Signal Detect Output Voltage – Low	V _{OL}			0.5	V	
Signal Detect Output Voltage – High	V _{OH}	2.0			V	

3. Measured at PRBS 2⁷-1 at BER=1E-12.
4. Represents sensitivity based on OMA spec., as corrected to incoming Extinction Ratio of 9 dB. For example, an OMA of 3.2 μW is approximately equal to an average power of -26.8 dBm, average with an Extinction ratio of 9 dB.
5. These outputs are compatible with 10K, 10KH and 100K ECL and PECL outputs.

CONNECTION DIAGRAM

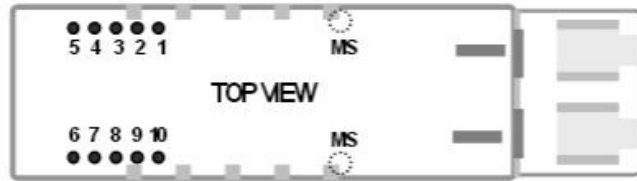

PIN	Symbol	Notes
1	V _{EE} RX	Directly connect this pin to the receiver ground plane
2	V _{CC} RX	+3.3V dc power for the receiver section
3	SD	Active high on this indicates a received optical signal.
4	RD-	Receiver Dataout Bar. See recommended circuit schematic
5	RD+	Receiver Dataout. See recommended circuit schematic
6	V _{CC} TX	+3.3V dc power for the transmitter section
7	V _{EE} TX	Directly connect this pin to the transmitter ground plane
8	TX_Disable	Transmitter Disable. Connect this pin to +3.3V TTL logic "1" to disable module To enable module connect to TTL logic low "0"
9	TD+	Transmitter Data In. See recommended circuit schematic
10	TD-	Transmitter Data In Bar. See recommended circuit schematic
MS	MS	Mounting Studs. Connect to Chassis Ground

RECOMMENDED CIRCUIT SCHEMATIC

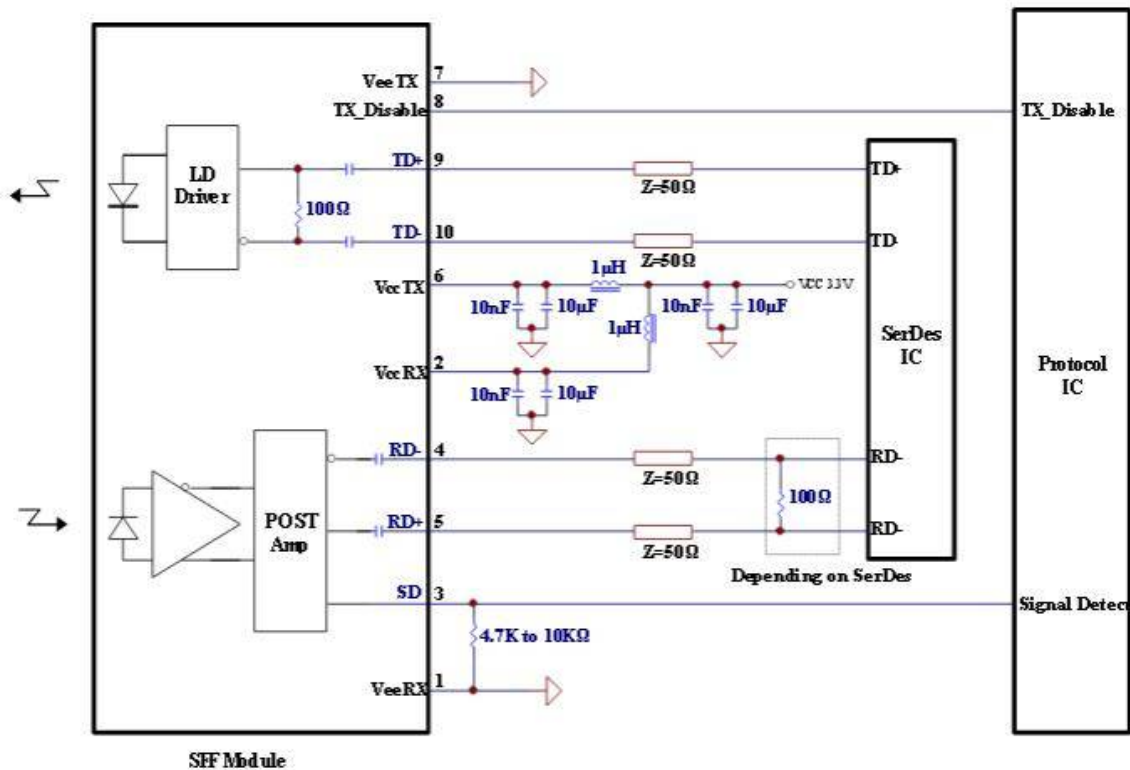

PACKAGE DIAGRAM (Units in mm)

A) Standard Case

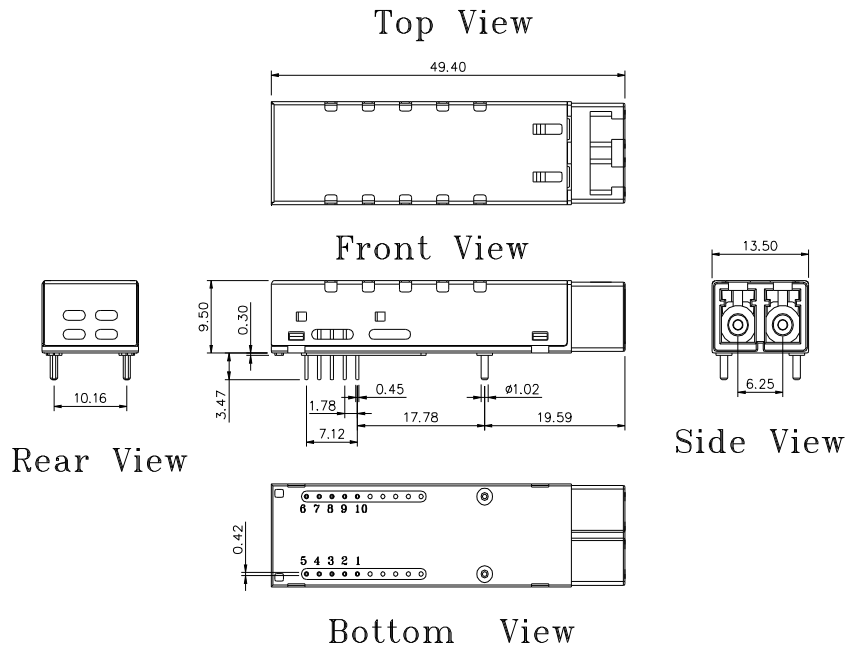

TRSL-8380G

B) Extended Case

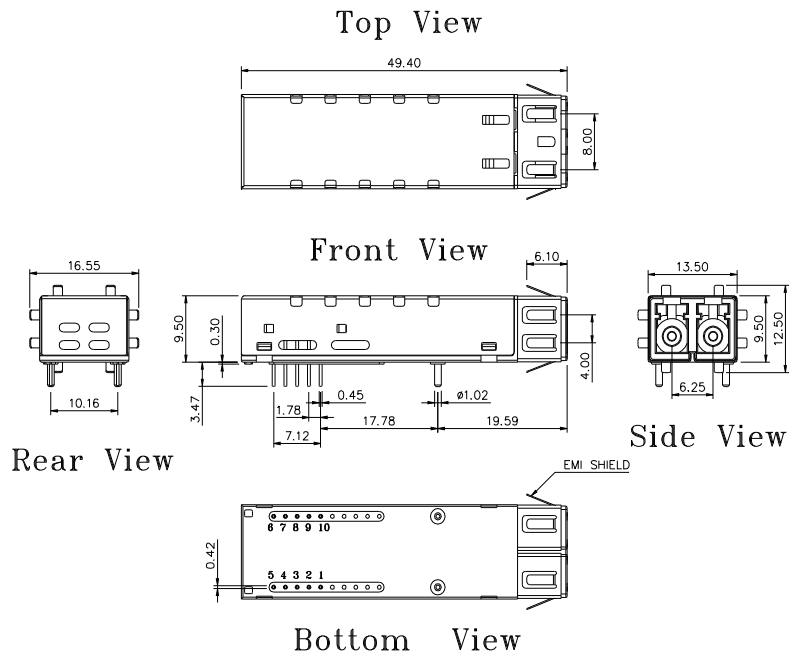

TRSL-8380EG

Note: Specifications subject to change without notice.

REVISION HISTORY

Version	Subject	Release Date
1.0	Initial datasheet	2007/02/01