

\*\*\*\*\*  
**TRSL-7130CG / TRSL-7130G / TRSL-7130ACG / TRSL-7130AG (RoHS Compliant)**  
**1.25 Gbps / 30 km / 1310 nm SFF LC SINGLE-MODE TRANSCEIVER**  
 \*\*\*\*\*

### FEATURES

- Duplex LC Single Mode Transceiver
- IEEE 802.3z 1000BASE-LX Compliant
- Fiber Channel 1X SM-LC-L FC-PI Compliant
- Small Form Factor, RJ-45 size, 2X5 pin Package
- 1310 nm LD Transmitter
- 19 dB Power Budget at Least
- Distance up to 30 km
- AC/AC Coupled Signal Input / Output
- LVTTTL Transmitter Disable Input
- LVTTTL Signal Detection Output: TRSL-7130CG
- LVPECL Signal Detection Output: TRSL-7130G
- Single +3.3 V Power Supply
- RoHS Compliant
- 0 to 70°C Operating: TRSL-7130CG
- -40 to 85°C Operating: TRSL-7130ACG
- Wave Solderable
- Class 1 Laser International Safety Standard IEC-60825 Compliant

### APPLICATIONS

- Gigabit Ethernet Switches and Routers
- Fiber Channel Switch Infrastructure
- Metro Edge Switching

### DESCRIPTION

The TRSL-7130CG series single mode transceivers is small form factor, low power, high performance module for bi-directional serial optical data communications such as IEEE 802.3z Gigabit Ethernet 1000BASE-LX and Fiber Channel 1X SM-LC-L FC-PI. This module is designed for single mode fiber and operates at a nominal wavelength of 1310 nm. A guaranteed minimum optical link budget of 16 dB is offered which can correspond to a link distance of over 30 km (assuming worst case fiber loss of 0.45 dB/km). The transmitter section uses a multiple quantum well laser and is a class 1 laser compliant according to International Safety Standard IEC-60825. The receiver section uses an integrated InGaAs detector preamplifier (IDP) mounted in an optical header and a limiting post-amplifier IC. A LVPECL logic interface simplifies interface to external circuitry.

### LASER SAFETY

This single mode transceiver is a Class 1 laser product. It complies with IEC-60825 and FDA 21 CFR 1040.10 and 1040.11. The transceiver must be operated within the specified temperature and voltage limits. The optical ports of the module shall be terminated with an optical connector or with a dust plug.

### ORDER INFORMATION

| P/No.        | Bit Rate (Gb/s) | 1000 BASE | Distance (km) | Wavelength (nm) | Package | Temp. (°C) | TX Power (dBm) | RX Sens. (dBm) | RoHS Compliant |
|--------------|-----------------|-----------|---------------|-----------------|---------|------------|----------------|----------------|----------------|
| TRSL-7130CG  | 1.25/1.063      |           | 30            | 1310            | 2X5 LC  | 0 to 70    | 0 to -5        | -24            | Yes            |
| TRSL-7130ACG | 1.25/1.063      |           | 30            | 1310 DFB        | 2X5 LC  | -40 to 85  | 0 to -5        | -24            | Yes            |

### Absolute Maximum Ratings

| Parameter             | Symbol | Min      | Max      | Units | Notes                       |
|-----------------------|--------|----------|----------|-------|-----------------------------|
| Storage Temperature   | Tstg   | -40      | 85       | °C    |                             |
| Operating Temperature | Topr   | 0<br>-40 | 70<br>85 | °C    | TRSL-7130CG<br>TRSL-7130ACG |
| Soldering Temperature | ---    |          | 260      | °C    | 10 seconds on leads only    |
| Power Supply Voltage  | Vcc    | 0        | 4.5      | V     |                             |
| Input Voltage         | ---    | GND      | Vcc      | V     |                             |
| Output Current        | Iout   | 0        | 30       | mA    |                             |

### Recommended Operating Conditions

| Parameter             | Symbol | Min      | Typ  | Max      | Units / Notes                         |
|-----------------------|--------|----------|------|----------|---------------------------------------|
| Power Supply Voltage  | Vcc    | 3.13     | 3.3  | 3.47     | V                                     |
| Operating Temperature | Topr   | 0<br>-40 |      | 70<br>85 | °C / TRSL-7130CG<br>°C / TRSL-7130ACG |
| Data Rate             |        | 1000     | 1250 |          | Mb/s                                  |
| Power Supply Current  | Icc    |          |      | 280      | mA                                    |

\*\*\*\*\*

| Transmitter Specifications (0°C < Topr < 70°C, 3.13V < Vcc < 3.47V) |                                   |                       |              |                 |       |                               |
|---|-----------------------------------|-----------------------|--------------|-----------------|-------|-------------------------------|
| Parameter   | Symbol                            | Min                   | Typ          | Max             | Units | Notes                         |
| <b>Optical</b>  |                                   |                       |              |                 |       |                               |
| Optical Transmit Power  | Po                                | -5                    | ---          | 0               | dBm   | 1                             |
| Output Center Wavelength  | $\lambda$                         | 1285<br>1270          | 1310<br>1310 | 1345<br>1360    | nm    | TRSL-7130CG<br>TRSL-7130ACG   |
| Output Spectrum Width   | $\Delta\lambda$                   |                       |              | 2               | nm    | RMS( $\sigma$ )/TRSL-7130CG   |
|   |                                   |                       |              | 1               | nm    | -20dB Width /<br>TRSL-7130ACG |
| Side Mode Suppression Ratio   | SMSR                              | 30                    |              |                 | dB    | TRSL-7130ACG                  |
| Extinction Ratio  | ER                                | 9                     | ---          | ---             | dB    |                               |
| Output Eye  | Compliant with IEEE 802.3z        |                       |              |                 |       |                               |
| Optical Rise Time   | t <sub>r</sub>                    |                       |              | 0.26            | ns    | 20% to 80% Values             |
| Optical Fall Time   | t <sub>f</sub>                    |                       |              | 0.26            | ns    | 20% to 80% Values             |
| Relative Intensity Noise  | RIN                               |                       |              | -120            | dB/Hz |                               |
| Total Jitter  | TJ                                |                       |              | 0.227           | ns    | 2                             |
| <b>Electrical</b>   |                                   |                       |              |                 |       |                               |
| Data Input Current – Low  | I <sub>IL</sub>                   | -350                  |              |                 | μA    |                               |
| Data Input Current – High   | I <sub>IH</sub>                   |                       |              | 350             | μA    |                               |
| Differential Input Voltage  | V <sub>IH</sub> - V <sub>IL</sub> | 300                   |              |                 | mV    |                               |
| Data Input Voltage – Low  | V <sub>IL</sub> - V <sub>CC</sub> | -2.0                  |              | -1.58           | V     | 3                             |
| Data Input Voltage -- High  | V <sub>IH</sub> - V <sub>CC</sub> | -1.1                  |              | -0.74           | V     | 3                             |
| Disable Input Voltage -- Low  | V <sub>TDISL</sub>                | 0                     |              | 0.5             | V     | TX Output Enabled             |
| Disable Input Voltage -- High                                       | V <sub>TDISH</sub>                | V <sub>CC</sub> - 1.3 |              | V <sub>CC</sub> | V     | TX Output Disabled            |
| Shut Off Time for TxDis   | t <sub>DIS</sub>                  |                       |              | 1               | ms    |                               |

- Notes: 1. Output power is power coupled into a 9/125 μm single mode fiber.  
 2. Measured with 2<sup>-1</sup> PRBS  
 3. These inputs are compatible with 10K, 10KH and 100K ECL and PECL inputs.

| Receiver Specifications (0°C < Topr < 70°C, 3.13V < Vcc < 3.47V) |                                   |      |     |       |       |                         |
|--|-----------------------------------|------|-----|-------|-------|-------------------------|
| Parameter  | Symbol                            | Min  | Typ | Max   | Units | Notes                   |
| <b>Optical</b>   |                                   |      |     |       |       |                         |
| Sensitivity  | ---                               | ---  | --- | -24   | dBm   | 1                       |
| Maximum Input Power  | P <sub>in</sub>                   | -3   |     | ---   | dBm   |                         |
| Signal Detect -- Asserted  | P <sub>a</sub>                    | ---  | --- | -24   | dBm   | Transition: low to high |
| Signal Detect -- Deasserted                                      | P <sub>d</sub>                    | -36  | --- | ---   | dBm   | Transition: high to low |
| Signal detect -- Hysteresis                                      |                                   | 1.0  | --- |       | dB    |                         |
| Wavelength of Operation  |                                   | 1100 | --- | 1600  | nm    |                         |
| <b>Electrical</b>  |                                   |      |     |       |       |                         |
| Data Output Voltage – Low  | V <sub>OL</sub> - V <sub>CC</sub> | -2.0 |     | -1.58 | V     | 2                       |
| Data Output Voltage – High                                       | V <sub>OH</sub> - V <sub>CC</sub> | -1.1 |     | -0.74 | V     | 2                       |
| Signal Detect Output Voltage -- Low                              | V <sub>OL</sub>                   |      |     | 0.5   | V     | TRSL-7130CG             |
| Signal Detect Output Voltage -- High                             | V <sub>OH</sub>                   | 2.0  |     |       | V     |                         |
| Signal Detect Output Voltage -- Low                              | V <sub>OL</sub> - V <sub>CC</sub> | -2.0 |     | -1.58 | V     | TRSL-7130G              |
| Signal Detect Output Voltage -- High                             | V <sub>OH</sub> - V <sub>CC</sub> | -1.1 |     | -0.74 | V     |                         |

- Notes: 1. Minimum sensitivity and saturation levels at BER=1E-12 for a 2<sup>-1</sup> PRBS.  
 2. These outputs are compatible with 10K, 10KH and 100K ECL and PECL outputs.

\*\*\*\*\*

### CONNECTION DIAGRAM



| PIN | Symbol    | Notes   |
|-----|-----------|---|
| 1   | $V_{EEr}$ | Directly connect this pin to the receiver ground plane  |
| 2   | $V_{CCr}$ | +3.3V dc power for the receiver section   |
| 3   | SD        | Active high on this indicates a received optical signal.  |
| 4   | RD-       | Receiver Data out Bar. See recommended circuit schematic  |
| 5   | RD+       | Receiver Data out. See recommended circuit schematic  |
| 6   | $V_{CCt}$ | +3.3V dc power for the transmitter section  |
| 7   | $V_{EEt}$ | Directly connect this pin to the transmitter ground plane   |
| 8   | TDIs      | Transmitter Disable. Connect this pin to +3.3V TTL logic "1" to disable module<br>To enable module connect to TTL logic low "0" |
| 9   | TD+       | Transmitter Data In. See recommended circuit schematic  |
| 10  | TD-       | Transmitter Data In Bar. See recommended circuit schematic  |
| MS  | MS        | Mounting Studs. Connect to Chassis Ground   |

### RECOMMENDED CIRCUIT SCHEMATIC

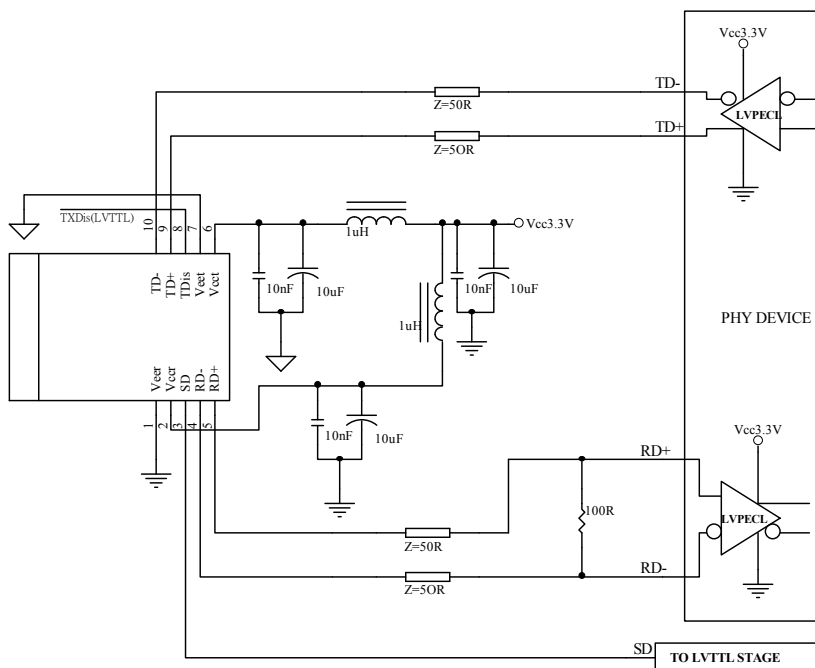

- Note:
1. TX input is terminated inside the module.
  2. 1000Ω SD Output pull-down resistor required for TRSL-7XX0G / TRSL-7XX0AG (LVPECL SD Output).
  3. Vee and Veet are not internally connected to each other.
  4. 50 Ω line pattern and component placements on TD+/TD- and RD+/RD- lines shall be symmetrical for better impedance matching.

\*\*\*\*\*  
**PACKAGE DIAGRAM**

Units in mm

1) Standard Case

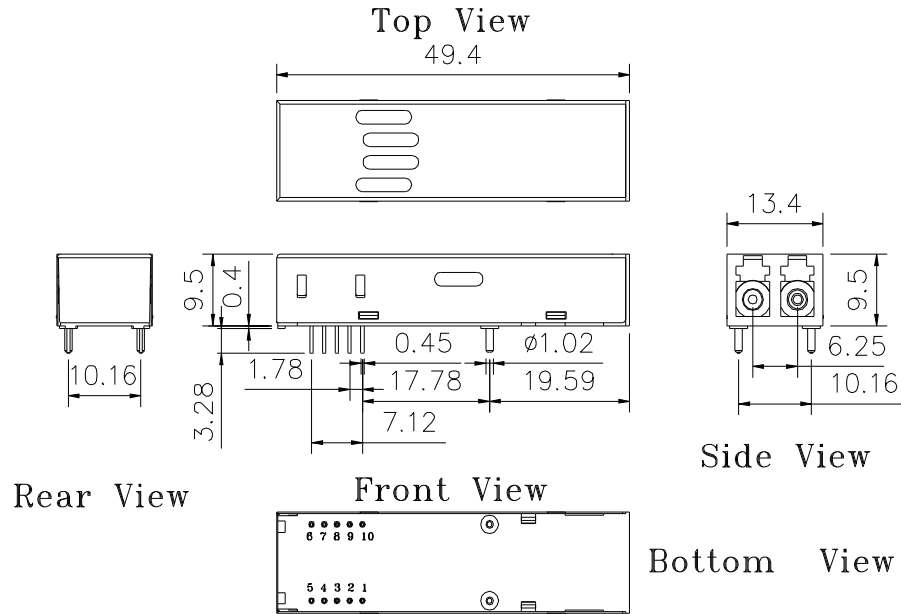

TRSL-7130G / TRSL-7130CG / TRSL-7130AG / TRSL-7130ACG

2) Extended Case

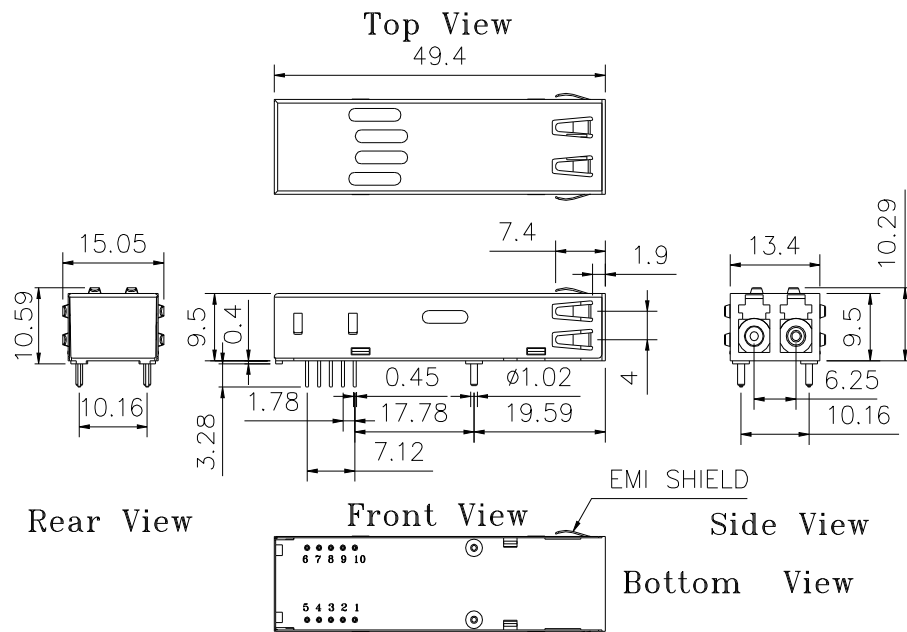

TRSL-7130EG / TRSL-7130CEG / TRSL-7130AEG / TRSL-7130ACEG

**Note:** Specifications subject to change without notice.