

BTRS-9600MG / BTRS-9600AMG

1310 nm TX / 1550 nm RX, 3.3V / 2.5 Gb/s **RoHS Compliant** Single-Fiber MM Transceiver

FEATURES

- Single Fiber Bi-Directional MM Transceiver
- Speed up to 2.67 Gb/s
- 1310 nm Transmitter
- 1550 nm Receiver
- Distance 0 to 300 m at 2.5 Gb/s
- 0 to 70°C Operating: BTRS-9600MG
- -40 to 85°C Operating: BTRS-9600AMG
- 2x5 Package with SC Receptacle
- LVTTTL Signal Detect Output
- Single +3.3 V Power Supply
- RoHS Compliant
- PECL Differential Inputs and Outputs
- Wave Solderable
- Class 1 Laser International Safety Standard IEC-60825 Compliant

APPLICATIONS

- WDM OC-48/STM-16 Links
- Gigabit Ethernet Interconnect
- Fiber Channel Links

DESCRIPTION

The BTRS-9600MG series are high performance modules for multi-mode single fiber communications by using 1310 nm transmitter and 1550 nm receiver. The transmitter section uses a multiple quantum well laser and is a class 1 laser compliant according to International Safety Standard IEC-60825. The receiver section uses an integrated 1550 nm detector preamplifier (IDP) mounted in an optical header and a limiting post-amplifier IC. A PECL logic interface simplifies interface to external circuitry. LV-TTL Signal Detect is used.

LASER SAFETY

This multi-mode transceiver is a Class 1 laser product. It complies with IEC-60825 and FDA 21 CFR 1040.10 and 1040.11. The transceiver must be operated within the specified temperature and voltage limits. The optical ports of the module shall be terminated with an optical connector or with a dust plug.

ORDER INFORMATION

P/No.	Bit Rate (Gb/s)	Distance (m)	TX (nm)	RX (nm)	Voltage (V)	Package	Temp. (°C)	TX Power (dBm)	RX Sens. (dBm)	RoHS Compliant
BTRS-9600MG	2.5	0 to 300	1310	1550	3.3	SC, 2X5	0 to 70	0 to -10	-16	Yes
BTRS-9600AMG	2.5	0 to 300	1310	1550	3.3	SC, 2X5	-40 to 85	0 to -10	-16	Yes

Absolute Maximum Ratings					
Parameter	Symbol	Min	Max	Units	Notes
Storage Temperature	Tstg	-40	85	°C	
Operating Temperature	Topr	0	70	°C	BTRS-9600MG
		-40	85		BTRS-9600AMG
Soldering Temperature	---		260	°C	10 seconds on leads only
Power Supply Voltage	Vcc	0	3.6	V	
Input Voltage	---	GND	Vcc	V	
Output Current	Iout	0	30	Ma	

Recommended Operating Conditions					
Parameter	Symbol	Min	Typ	Max	Units / Notes
Power Supply Voltage	Vcc	3.13	3.3	3.47	V
Operating Temperature	Topr	0		70	°C / BTRS-9600MG
		-40		85	°C / BTRS-9600AMG
Data Rate		1000	2488	2670	Mb/s
Power Supply Current	Icc			260	mA

Transmitter Specifications (0°C < Topr < 70°C, 3.13V < Vcc < 3.47V)

Parameter	Symbol	Min	Typ	Max	Units	Notes
Optical						
Optical Transmit Power	Po	-10		0	dBm	1
Output Center Wavelength	λ	1270	1310	1360	nm	
Output Spectrum Width	σ_{λ}			4	nm	RMS(σ)
Output Eye	Compliant with IEEE 802.3z					
Optical Rise Time	t_r			150	ps	20% to 80% Values
Optical Fall Time	t_f			150	ps	20% to 80% Values
Relative Intensity Noise	RIN			-120	dB/Hz	
Electrical						
Data Input Current – Low	I _{IL}	-350			μ A	
Data Input Current – High	I _{IH}			350	μ A	
Differential Input Voltage	V _{IH} - V _{IL}	300		1600	mV	
Data Input Voltage – Low	V _{IL} - V _{CC}	-2.0		-1.58	V	2
Data Input Voltage -- High	V _{IH} - V _{CC}	-1.1		-0.74	V	2
Disable Input Voltage -- Low	V _{TDIS,L}	0		0.8	V	TX Output Enabled
Disable Input Voltage – High	V _{TDIS,H}	Vcc-1.3		Vcc	V	TX Output Disabled
Shut Off Time for TxDis	t _{DIS}			1	ms	

- Notes: 1. Output power is power coupled into a 62.5/125 μ m multi- mode fiber.
 2. These inputs are compatible with 10K, 10KH and 100K ECL and LVPECL inputs.

Receiver Specifications (0°C < Topr < 70°C, 3.13V < Vcc < 3.47V)

Parameter	Symbol	Min	Typ	Max	Units	Notes
Optical						
Sensitivity	---	---	---	-16	dBm	1
Maximum Input Power	P _{in}	-3		---	dBm	
Signal Detect -- Asserted	P _a	---	---	-16	dBm	Transition: low to high
Signal Detect -- Deasserted	P _d	-31	---	---	dBm	Transition: high to low
Signal detect -- Hysteresis		1.0	---		dB	
Wavelength of Operation		1480	---	1580	Nm	2
Optical Return Loss	ORL	20			dB	
Electrical						
Data Output Voltage Swing	V _{OH} - V _{OL}	0.575		0.930	V	
SD Output Voltage -- Low	V _{OL}	0		0.8	V	
SD Output Voltage -- High	V _{OH}	2.0		Vcc+ 0.3	V	
Signal Detect Assert Time	AS _{MAX}			100	μ s	OFF to ON
Signal Detect Deassert Time	ANS _{MAX}			300	μ s	ON to OFF

- Notes: 1. Minimum sensitivity and saturation levels at BER=1E-10 for a 2²³-1 PRBS.
 2. At least 30 dB optical isolation for the wavelength 1260 to 1360 nm.

CONNECTION DIAGRAM

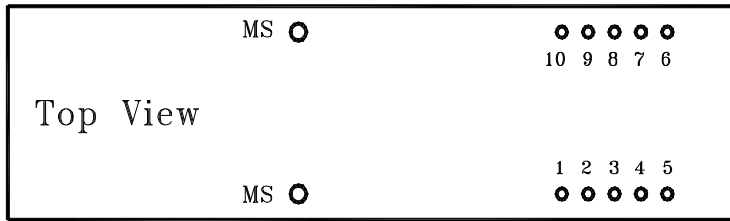

PIN	Symbol	Notes
1	V _{EEf}	Directly connect this pin to the receiver ground plane
2	V _{CCf}	+3.3V dc power for the receiver section
3	SD	Active high on this indicates a received optical signal.
4	RD-	Receiver Data out Bar. See recommended circuit schematic
5	RD+	Receiver Data out.. See recommended circuit schematic
6	V _{CCt}	+3.3V dc power for the transmitter section
7	V _{EEt}	Directly connect this pin to the transmitter ground plane
8	TxDIs	Transmitter Disable. Connect this pin to +3.3V TTL logic "1" to disable module To enable module connect to TTL logic low "0"
9	TD+	Transmitter Data in.. See recommended circuit schematic
10	TD-	Transmitter Data in Bar. See recommended circuit schematic
MS	MS	Mounting Studs. Connect to Chassis Ground

RECOMMENDED CIRCUIT SCHEMATIC

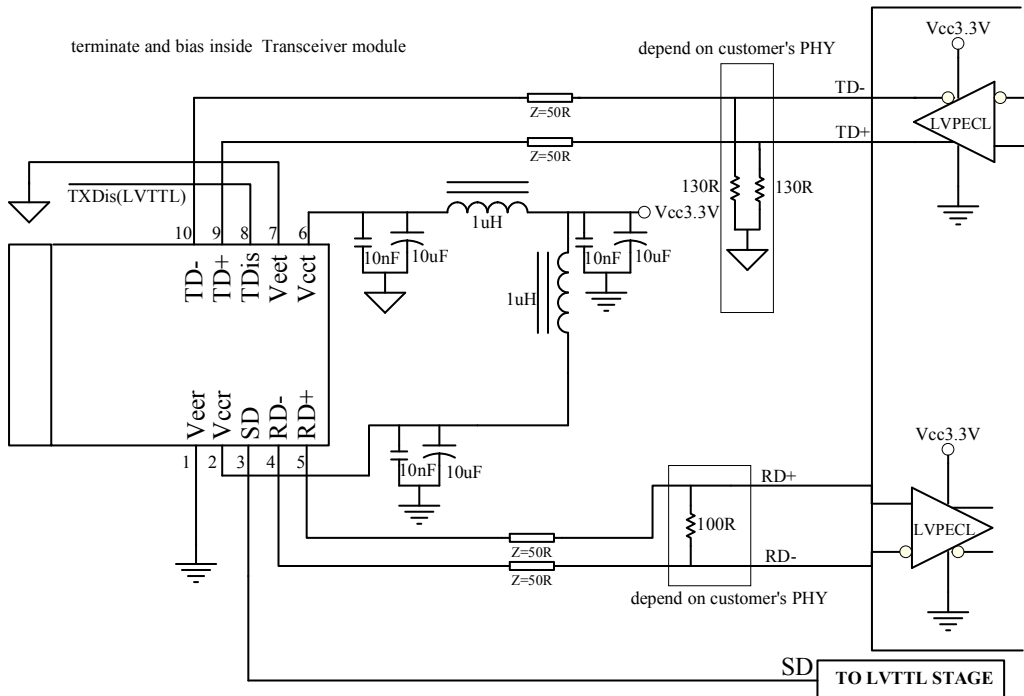

PACKAGE DIAGRAM

Units in mm

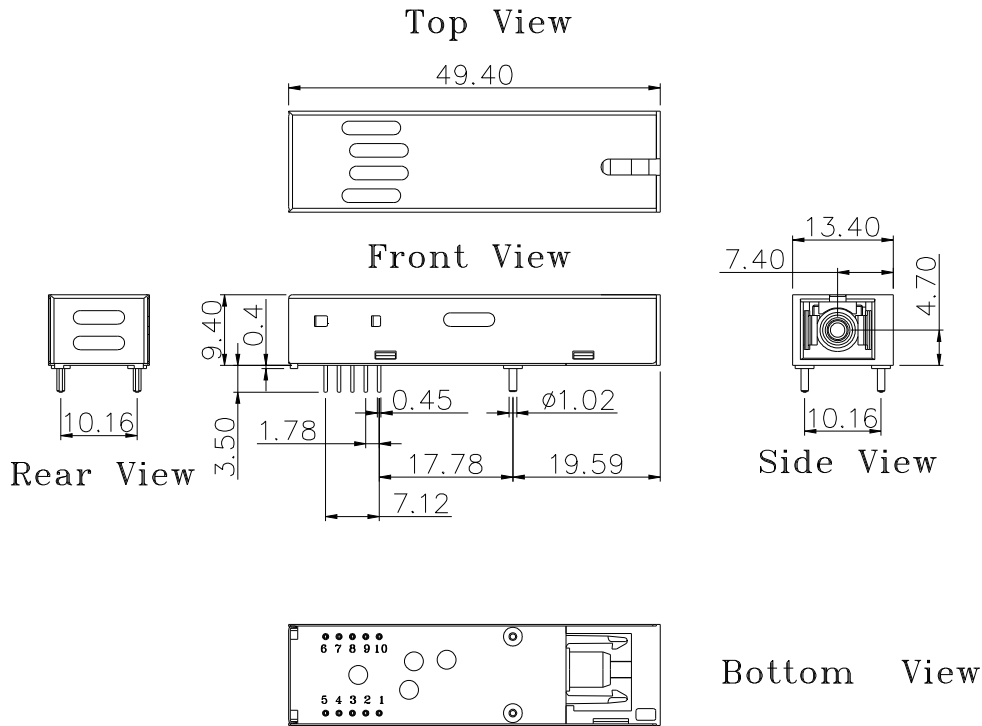

Note: Specifications subject to change without notice.