

### BTRS-7920CG / BTRS-7920C-SPG / BTRS-7920ACG / BTRS-7920AC-SPG

### 1490 nm TX / 1310 nm RX, 3.3V / 1250 Mbps **RoHS Compliant** Single-Fiber Transceiver

#### FEATURES

- Bi-Directional Single Fiber Transceiver
- Compliant with IEEE 802.3ah 1000BASE-BX10
- 1490 nm DFB LD Transmitter
- 1310 nm Receiver
- 14 dB Power Budget At Least
- Link distance up to 20 km
- Single +3.3 V Power Supply
- RoHS Compliant
- 0 to 70°C Operating: BTRS-7920CG
- -40 to 85°C Operating: BTRS-7920ACG
- LVPECL Differential Inputs and Outputs
- LVTTTL Signal Detect Output
- Wave Solderable
- Class 1 Laser International Safety Standard IEC-60825 Compliant

#### APPLICATIONS

- WDM Gigabit Ethernet Links
- SONET/SDH Equipment Interconnect
- Fiber Channel Links

#### DESCRIPTION

The BTRS-7920CG series are high performance modules for single fiber communications by using 1490 nm transmitter and 1310 nm receiver. The transmitter section uses a multiple quantum well laser and is a class 1 laser compliant according to International Safety Standard IEC-60825. The receiver section is designed to receive 1310 nm and block 1490 nm signal. This feature is suitable for IEEE 802.3ah 1000BASE-BX and ITU-T 983.3 application. A PECL logic interface simplifies interface to external circuitry. LVTTTL signal Detect is used.

#### LASER SAFETY

This multi-mode transceiver is a Class 1 laser product. It complies with IEC-60825 and FDA 21 CFR 1040.10 and 1040.11. The transceiver must be operated within the specified temperature and voltage limits. The optical ports of the module shall be terminated with an optical connector or with a dust plug.

#### ORDER INFORMATION

P/No.	IEEE 802.3ah 1000BASE	Bit Rate (Gb/s)	Distance (km)	TX (nm)	RX (nm)	Voltage (V)	Package	Temp. (°C)	TX Power (dBm)	RX Sens. (dBm)	RoHS Compliant
BTRS-7920CG	BX	1.25	20	1490 DFB	1310	3.3	SC, 2X5	0 to 70	-3 to -8	-22	Yes
BTRS-7920ACG	BX	1.25	20	1490 DFB	1310	3.3	SC, 2X5	-40 to 85	-3 to -8	-22	Yes

Note: 1. BTRS-XXXXXXG is SC/PC receptacle type package with standard case.

2. BTRS-XXXXXX-APBBBG is SFF pigtail type package with different connector, A=S is SC connector, A=F is FC connector, A=T is ST connector, A=L is LC connector, A=M is MU connector, BBB is the length of fiber in cm.

Absolute Maximum Ratings					
Parameter	Symbol	Min	Max	Units	Notes
Storage Temperature	Tstg	-40	85	°C	
Operating Temperature	Topr	0	70	°C	BTRS-7920CG
		-40	85		BTRS-7920ACG/air flow 1m/sec
Soldering Temperature	---		260	°C	10 seconds on leads only
Power Supply Voltage	Vcc	0	3.6	V	
Input Voltage	---	GND	Vcc	V	
Output Current	Iout	0	30	mA	

Recommended Operating Conditions					
Parameter	Symbol	Min	Typ	Max	Units / Notes
Power Supply Voltage	Vcc	3.13	3.3	3.47	V
Operating Temperature	Topr	0		70	°C / BTRS-7920CG
		-40		85	°C / BTRS-7920ACG air flow 1m/sec
Data Rate			1250	1300	Mb/s
Power Supply Current	Icc			280	mA

\*\*\*\*\*

Transmitter Specifications (0°C < Topr < 70°C, 3.13V < Vcc < 3.47V)						
Parameter	Symbol	Min	Typ	Max	Units	Notes
<b>Optical</b>						
Optical Transmit Power	P <sub>o</sub>	-8		-3	dBm	1
Output Center Wavelength	λ	1480		1500	nm	
Output Spectrum Width	Δλ	---	---	1	nm	-20 dB Width
Extinction Ratio	E <sub>R</sub>	9			dB	
Output Eye	Compliant with IEEE 802.3z					
Optical Rise Time	t <sub>r</sub>			0.26	ns	20% to 80% Values
Optical Fall Time	t <sub>f</sub>			0.26	ns	20% to 80% Values
Relative Intensity Noise	RIN			-120	dB/Hz	
Total Jitter	TJ			0.227	ns	2
<b>Electrical</b>						
Data Input Current – Low	I <sub>IL</sub>	-350			μA	
Data Input Current – High	I <sub>IH</sub>			350	μA	
Differential Input Voltage	V <sub>IH</sub> - V <sub>IL</sub>	300		1600	mV	
Data Input Voltage – Low	V <sub>IL</sub> - V <sub>CC</sub>	-2.0		-1.58	V	3
Data Input Voltage -- High	V <sub>IH</sub> - V <sub>CC</sub>	-1.1		-0.74	V	3
Disable Input Voltage -- Low	V <sub>TDIS,L</sub>	0		0.8	V	TX Output Enabled
Disable Input Voltage – High	V <sub>TDIS,H</sub>	V <sub>CC</sub> -1.3		V <sub>CC</sub>	V	TX Output Disabled
Shut Off Time for TxDis	t <sub>DIS</sub>			1	ms	

- Notes: 1. Output power is power coupled into a 9/125 μm single- mode fiber.  
 2. Measure with 2<sup>7</sup>-1 PRBS.  
 3. These inputs are compatible with 10K, 10KH and 100K ECL and LVPECL inputs.

Receiver Specifications (0°C < Topr < 70°C, 3.13V < Vcc < 3.47V)						
Parameter	Symbol	Min	Typ	Max	Units	Notes
<b>Optical</b>						
Sensitivity	---	---	---	-22	dBm	1
Maximum Input Power	P <sub>in</sub>	-3		---	dBm	
Signal Detect -- Asserted	P <sub>a</sub>	---	---	-22	dBm	Transition: low to high
Signal Detect -- Deasserted	P <sub>d</sub>	-31	---	---	dBm	Transition: high to low
Signal detect -- Hysteresis		1.0	---		dB	
Wavelength of Operation		1260		1360	Nm	2
Optical Return Loss	ORL	20			dB	
<b>Electrical</b>						
Data Output Voltage Swing	V <sub>OH</sub> - V <sub>OL</sub>	0.575		0.930	V	
SD Output Voltage -- Low	V <sub>OL</sub>	0		0.8	V	
SD Output Voltage -- High	V <sub>OH</sub>	2.0		V <sub>CC</sub> + 0.3	V	
Signal Detect Assert Time	A <sub>S</sub> <sub>MAX</sub>			100	μs	OFF to ON
Signal Detect Deassert Time	A <sub>N</sub> <sub>MAX</sub>			300	μs	ON to OFF

- Notes: 1. Minimum sensitivity and saturation levels at BER=1E-12 for a 2<sup>7</sup>-1 PRBS.  
 2. At least 30 dB optical isolation for the wavelength 1480 to 1500 nm.  
 3. At least 30 dB optical isolation for the wavelength 1550 to 1600 nm.

### CONNECTION DIAGRAM



PIN	Symbol	Notes
1	$V_{EEf}$	Directly connect this pin to the receiver ground plane
2	$V_{CCf}$	+3.3V dc power for the receiver section
3	SD	Active high on this indicates a received optical signal.
4	RD-	Receiver Data out Bar. See recommended circuit schematic
5	RD+	Receiver Data out.. See recommended circuit schematic
6	$V_{CCt}$	+3.3V dc power for the transmitter section
7	$V_{EEt}$	Directly connect this pin to the transmitter ground plane
8	TxDIs	Transmitter Disable. Connect this pin to +3.3V TTL logic "1" to disable module To enable module connect to TTL logic low "0"
9	TD+	Transmitter Data in.. See recommended circuit schematic
10	TD-	Transmitter Data in Bar. See recommended circuit schematic
MS	MS	Mounting Studs. Connect to Chassis Ground

### RECOMMENDED CIRCUIT SCHEMATIC

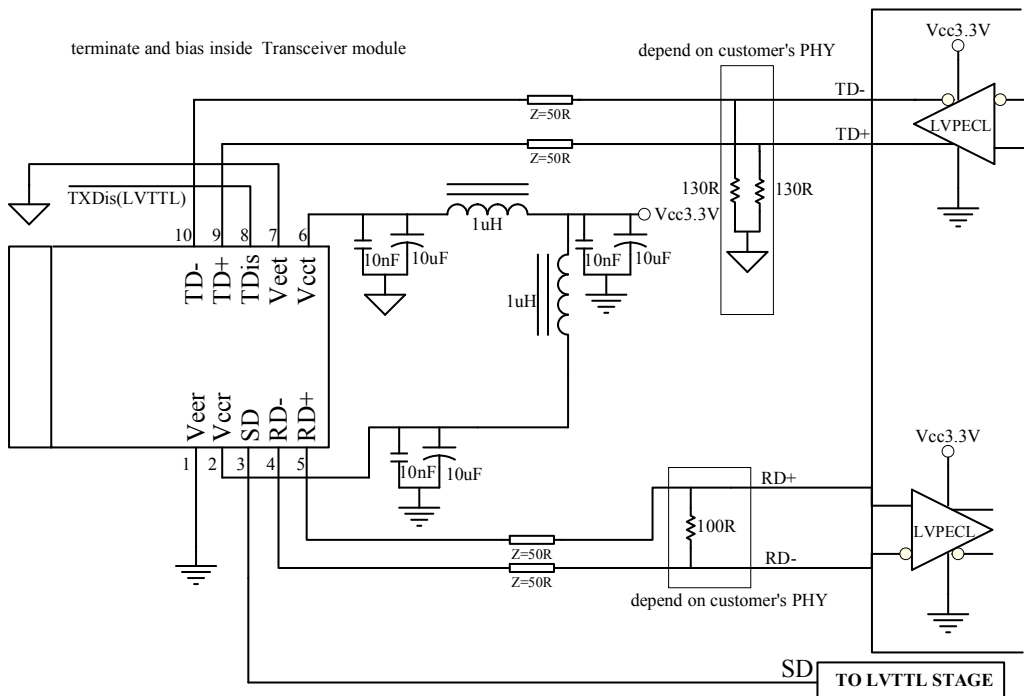

### PACKAGE DIAGRAM

Units in mm

#### 1) SC Receptacle

##### A) Standard Case

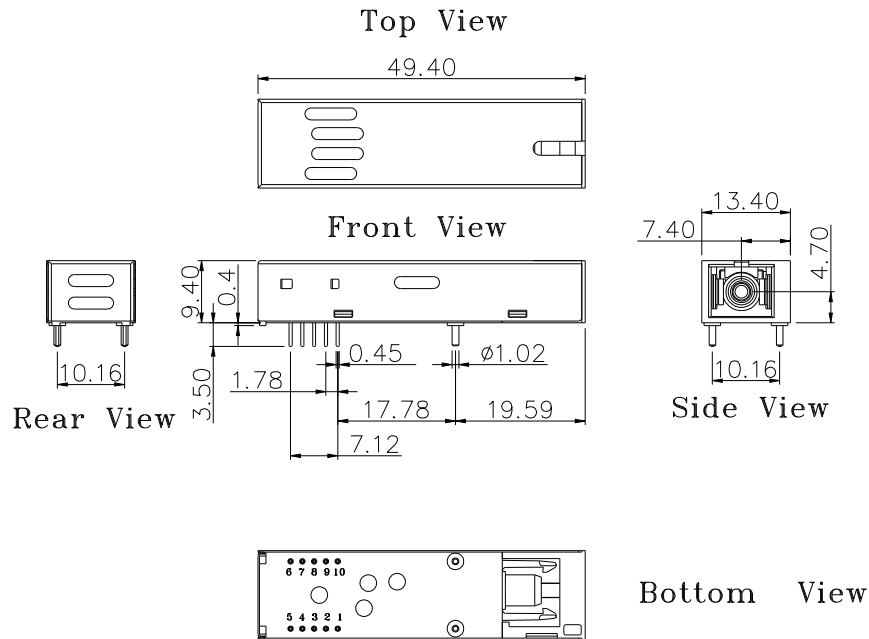

BTRS-7920CG / BTRS-7920ACG

##### B) Extended Case

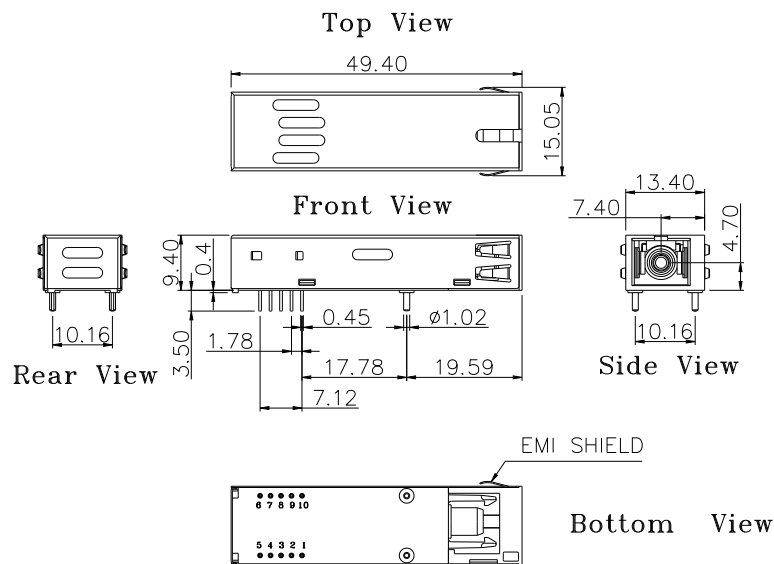

BTRS-7920CEG / BTRS-7920ACEG

### 2) Pigtail

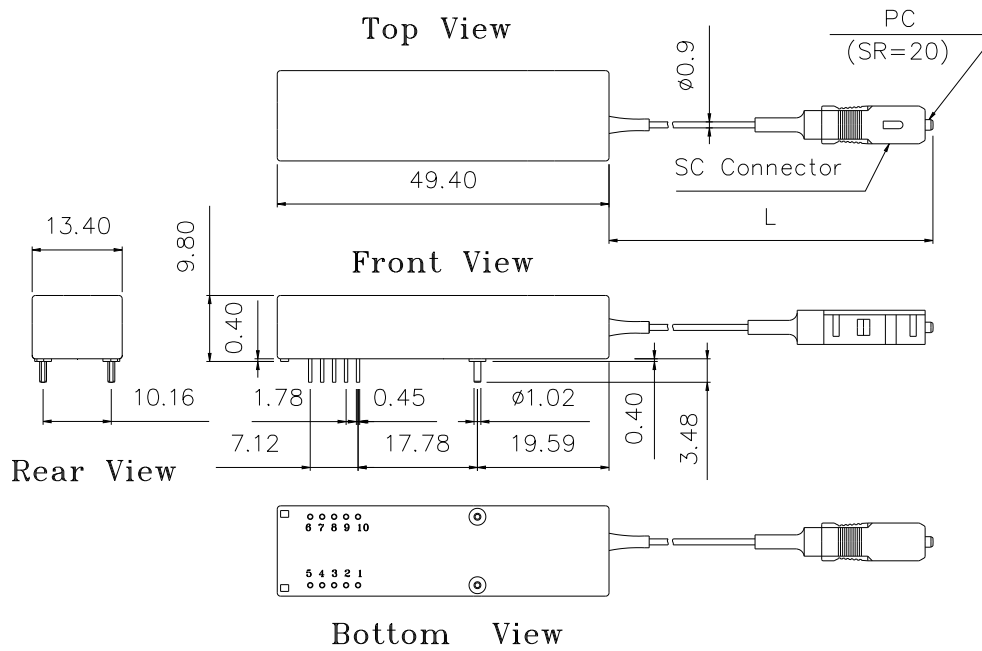

BTRS-7920C-SP50G / BTRS-7920AC-SP50G

Note: Length L is  $50 \pm 3$  cm. Other pigtail's length is available upon request.

Note: Specifications subject to change without notice.