TRS-3120G / TRS-3120TG / TRS-3120FG

3.3V / 1310 nm / 155 Mbps **RoHS Compliant Optical Single-Mode Transceiver**

FEATURES

- Duplex SC Single Mode Transceiver: TRS-3120G
- Duplex ST Single Mode Transceiver: TRS-3120TG
- Duplex FC Single Mode Transceiver: TRS-3120FG
- Distance up to 20 km
- Industry Standard 1 x 9 Footprint
- Single +3.3 V Power Supply
- **RoHS Compliant**
- 0 to 70°C Operating
- PECL Signal Detection Output
- LED Multisourced 1 x 9 Transceiver Interchangeable
- Wave Solderable
- Class 1 Laser International Safety Standard IEC 825 Compliant

APPLICATIONS

- ATM 155 Mbps Links
- SONET / SDH Equipment Interconnect
- Fast Ethernet 100 Mb/s Links

DESCRIPTION

The TRS-3120G series single mode transceiver is a low power, high performance module for bi-directional serial optical data communications such as SONET OC-3 / SDH STM-1 and Fast Ethernet. This module is designed for single mode fiber and operates at a nominal wavelength of 1310 nm. The transmitter section uses a multiple quantum well laser and is a class 1 laser compliant according to International Safety Standard IEC-825. The receiver section uses an integrated InGaAs detector preamplifier (IDP) mounted in an optical header and a limiting post-amplifier IC. A PECL logic interface simplifies interface to external circuitry.

LASER SAFETY

This single mode transceiver is a Class 1 laser product. It complies with IEC 60825 and FDA 21 CFR 1040.10 and 1040.11. The transceiver must be operated within the specified temperature and voltage limits. The optical ports of the module shall be terminated with an optical connector or with a dust plug.

ORDER INFORMATION

P/No.	Bit Rate (Mb/s)	SONET / SDH	Distance (km)	Wavelength (nm)	Voltage (V)	Package	Temp. (°C)	TX Power (dBm)	RX Sens. (dBm)	RoHS Compliant
TRS-3120G	155		20	1310	3.3	1X9 SC/ST/FC	0 to 70	-7 to -18	-32	Y

Absolute Maximum Ratings

Parameter	Symbol	Min	Max	Units	Notes
Storage Temperature	Tstg	-40	85	°C	
Operating Temperature	Topr	0	70	°C	
Soldering Temperature	---		260	°C	10 seconds on leads only
Power Supply Voltage	Vcc	0	4.5	V	
Input Voltage	---	GND	Vcc	V	
Output Current	Iout	0	30	mA	

Recommended Operating Conditions

Parameter	Symbol	Min	Typ	Max	Units
Power Supply Voltage	Vcc	3.1	3.3	3.5	V
Operating Temperature	Topr	0		70	°C
Data Rate			155		Mb/s
Power Supply Current	Icc			240	mA

Transmitter Specifications (0°C < Topr < 70°C, 3.1V < Vcc < 3.5V)						
Parameter	Symbol	Min	Typ	Max	Units	Notes
Optical						
Optical Transmit Power	Po	-18	---	-7	dBm	1
Output Center Wavelength	λ	1261	1310	1360	nm	
Output Spectrum Width	$\Delta\lambda$	---	---	7.7	nm	RMS(σ)
Extinction Ratio	E_R	8.2	---	---	dB	
Output Eye	Compliant with Bellcore TR-NWT-000253 and ITU recommendation G.957					
Optical Rise Time	t_r			2	ns	10% to 90% Values
Optical Fall Time	t_f			2	ns	10% to 90% Values
Relative Intensity Noise	RIN			-116	dB/Hz	
Total Jitter	TJ			1	ns	2
Electrical						
Data Input Current – Low	I_{IL}	-350			μ A	
Data Input Current – High	I_{IH}			350	μ A	
Differential Input Voltage	$V_{IH} - V_{IL}$	300			mV	
Data Input Voltage – Low	$V_{IL} - V_{CC}$	-2.0		-1.58	V	3
Data Input Voltage -- High	$V_{IH} - V_{CC}$	-1.1		-0.74	V	3

- Notes: 1. Output power is power coupled into a 9/125 μ m single mode fiber.
 2. Measured with a 2^{23} -1 PRBS with 72 ones and 72 zeros.
 3. These inputs are compatible with 10K, 10KH and 100K ECL and PECL inputs.

Receiver Specifications (0°C < Topr < 70°C, 3.1V < Vcc < 3.5V)						
Parameter	Symbol	Min	Typ	Max	Units	Notes
Optical						
Sensitivity	---	---	---	-32	dBm	1
Maximum Input Power	P _{in}	-3		---	dBm	
Signal Detect -- Asserted	P _a	---	---	-32	dBm	Transition: low to high
Signal Detect -- Deasserted	P _d	-47	---	---	dBm	Transition: high to low
Signal detect -- Hysteresis		1.0	---		dB	
Wavelength of Operation		1100	---	1600	nm	
Electrical						
Data Output Voltage – Low	$V_{OL} - V_{CC}$	-2.0		-1.58	V	2
Data Output Voltage – High	$V_{OH} - V_{CC}$	-1.1		-0.74	V	2
Signal Detect Output Voltage -- Low	$V_{OL} - V_{CC}$	-2.0		-1.58	V	
Signal Detect Output Voltage -- High	$V_{OH} - V_{CC}$	-1.1		-0.74	V	

- Notes: 1. Minimum sensitivity and saturation levels at BER=1E-10 for a 2^{23} -1 PRBS with 72 ones and 72 zeros.
 2. These outputs are compatible with 10K, 10KH and 100K ECL and PECL outputs.

CONNECTION DIAGRAM

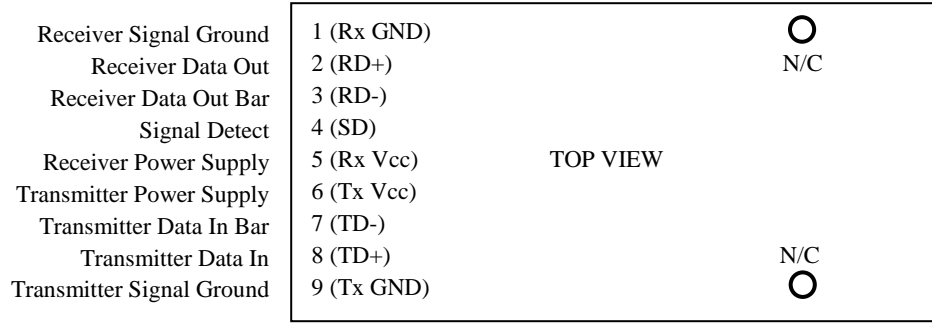

PIN	Symbol	Notes
1	Rx GND	Directly connect this pin to the receiver ground plane
2	RD+	See recommended circuit schematic
3	RD-	See recommended circuit schematic
4	SD	Active high on this indicates a received optical signal
5	Rx Vcc	+3.3V dc power for the receiver section
6	Tx Vcc	+3.3V dc power for the transmitter section
7	TD-	See recommended circuit schematic
8	TD+	See recommended circuit schematic
9	Tx GND	Directly connect this pin to the transmitter ground plane

RECOMMENDED CIRCUIT SCHEMATIC

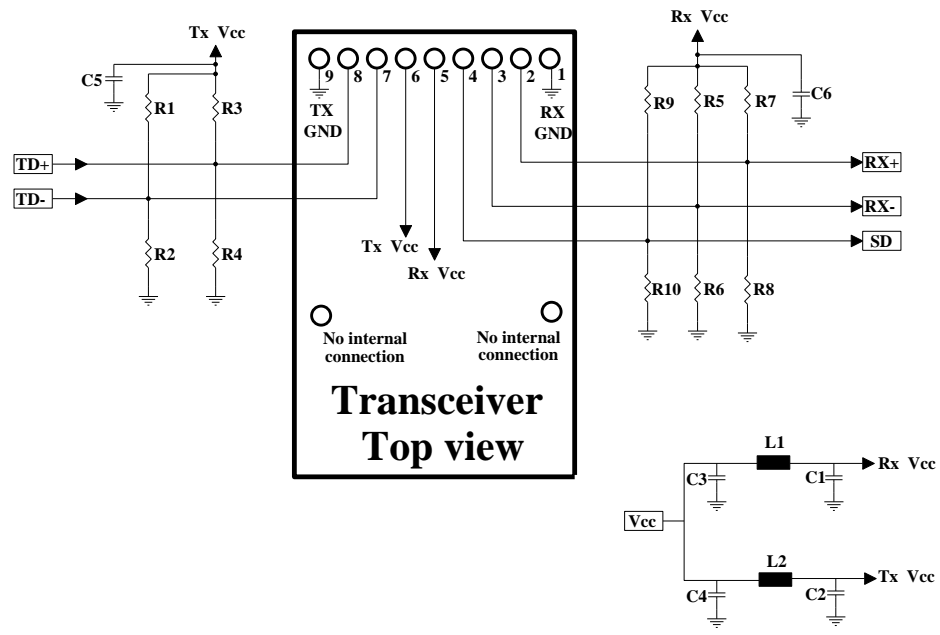

R1=R3=R5=R7=R9=130 ohm
R2=R4=R6=R8=R10=82 ohm
C1=C2=C3=C5=C6=0.1 Uf
C4=10uF L1=L2=1uH

The split-load terminations for ECL signals need to be located at the input of devices receiving those ECL signals. The power supply filtering is required for good EMI performance. Use short tracks from the inductor L1/L2 to the module Rx Vcc and Tx Vcc. A GND plane under the module is required for good EMI and sensitivity performance.

PACKAGE DIAGRAM

Units in mm

1) SC Type

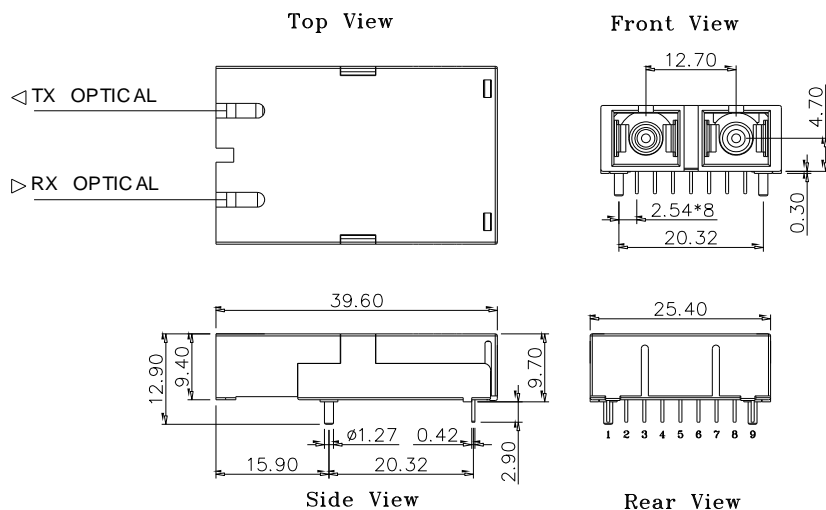

TRS-3120G

2) ST Type

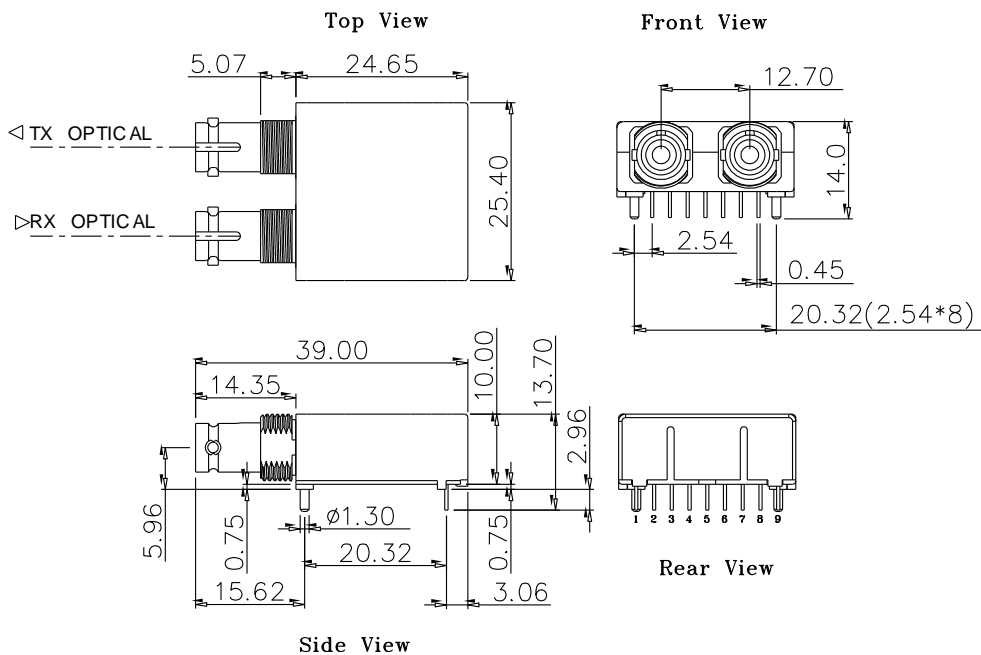

TRS-3120TG

3) FC Type

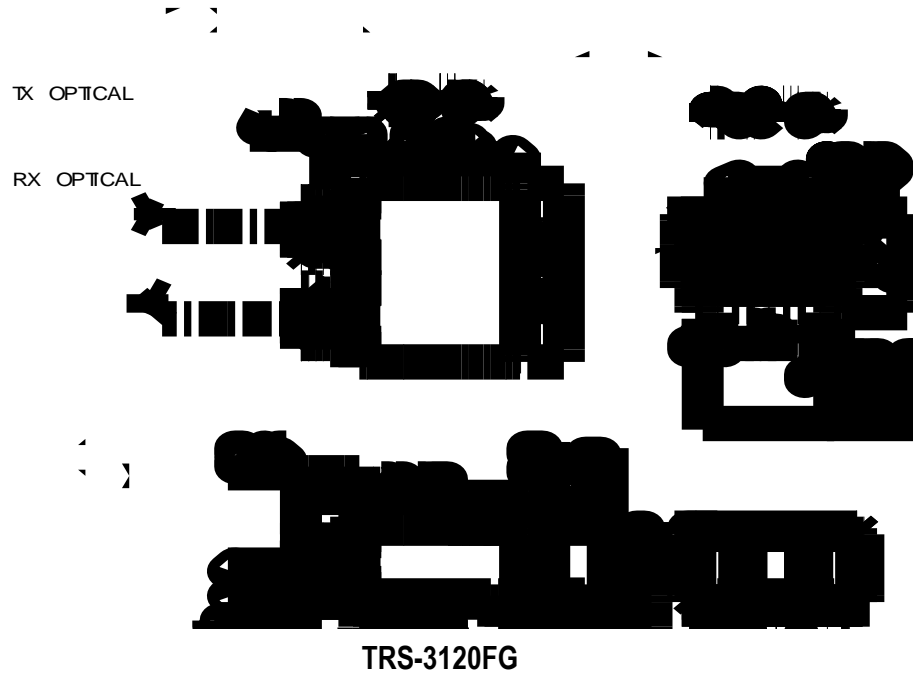

Note: Specifications subject to change without notice.