TRM-7100G / TRM-7100CG / TRM-7100AG / TRM-7100ACG

3.3V / 850 nm / 1.25 Gbps RoHS Compliant Optical Multi-Mode Transceiver

FEATURES

- Duplex SC Multi-Mode Transceiver
- Compliant with IEEE-802.3z 1000BASE-SX
- Industry Standard 1 x 9 Footprint
- 850 nm VCSEL Transmission
- 0 to 70°C Operating: TRM-7100G / TRM-7100FG
- -40 to 85°C Operating: TRM-7100AG / TRM-7100AFG
- Single +3.3 V Power Supply
- RoHS Compliant
- 300 meter with 62.5/125 μm MMF
- 550 meter with 50/125 μm MMF
- LVPECL Signal Detect Output: TRM-7100G
- LVTTTL Signal Detect Output: TRM-7100CG
- Wave Solderable
- Class 1 Laser International Safety Standard IEC 60825-1 Compliant

APPLICATIONS

- Switch to Switch Interface
- High Speed Interface for File Servers
- High Performance Desktops

DESCRIPTION

The TRM-7100G series multi-mode transceiver is a low power, high performance module for bi-directional serial optical data communications such Gigabit Ethernet and Fibre Channel. This module is designed for multi-mode fiber and operates at a nominal wavelength of 850 nm. The transmitter section uses a multiple quantum well VCSEL and is a class 1 laser compliant according to International Safety Standard IEC-60825-1. The receiver section uses an integrated GaAs detector preamplifier (IDP) mounted in an optical header and a limiting post-amplifier IC. A PECL logic interface simplifies interface to external circuitry.

LASER SAFETY

This multi-mode transceiver is a Class 1 laser product. It complies with IEC 60825-1 and FDA 21 CFR 1040.10 and 1040.11. The transceiver must be operated within the specified temperature and voltage limits. The optical ports of the module shall be terminated with an optical connector or with a dust plug.

ORDER INFORMATION

P/No.	Distance (m)	Wavelength (nm)	Voltage (V)	Package	Temp. (°C)	TX Power (dBm)	RX Sens. (dBm)	Signal Detect	RoHS Compliant
TRM-7100G	300 / 550*	850	3.3	1X9 SC	0 to 70	-4 to -9.5	-18	LVPECL	Yes
TRM-7100CG	300 / 550*	850	3.3	1X9 SC	0 to 70	-4 to -9.5	-18	LVTTTL	Yes
TRM-7100FG	300 / 550*	850	3.3	1X9 FC	0 to 70	-4 to -9.5	-18	LVPECL	Yes
TRM-7100CFG	300 / 550*	850	3.3	1X9 FC	0 to 70	-4 to -9.5	-18	LVTTTL	Yes
TRM-7100AG	300 / 550*	850	3.3	1X9 SC	-40 to 85	-4 to -9.5	-18	LVPECL	Yes
TRM-7100ACG	300 / 550*	850	3.3	1X9 SC	-40 to 85	-4 to -9.5	-18	LVTTTL	Yes
TRM-7100AFG	300 / 550*	850	3.3	1X9 FC	-40 to 85	-4 to -9.5	-18	LVPECL	Yes
TRM-7100ACFG	300 / 550*	850	3.3	1X9 FC	-40 to 85	-4 to -9.5	-18	LVTTTL	Yes

Note: Distance 300 m for 62.5/125μm MMF, 550 m for 50/125 μm MMF

Absolute Maximum Ratings					
Parameter	Symbol	Min	Max	Units	Notes
Storage Temperature	Tstg	-40	85	°C	
Operating Temperature	Topr	0	70	°C	TRM-7100G
		-40	85		TRM-7100AG
Soldering Temperature	---		260	°C	10 seconds on leads only
Power Supply Voltage	Vcc	-0.5	4.5	V	
Input Voltage	---	GND	Vcc	V	
Output Current	Iout	0	30	mA	

Recommended Operating Conditions					
Parameter	Symbol	Min	Typ	Max	Units
Power Supply Voltage	Vcc	3.1	3.3	3.5	V
Operating Temperature	Topr	0		70	°C / TRM-7100G
		-40		85	°C / TRM-7100AG
Data Rate		100	1250		Mb/s

Transmitter Specifications (0°C < Topr < 70°C, 3.1V < Vcc < 3.5V)						
Parameter	Symbol	Min	Typ	Max	Units	Notes
Optical						
Optical Transmit Power 62.5/125μm, NA=0.275 Fiber	Po	-9.5	---	-4	dBm	
Optical Transmit Power 50/125μm, NA=0.20 Fiber	Po	-9.5	---	-4	dBm	
Output Center Wavelength	λ	830	850	860	nm	
Output Spectrum Width	Δλ	---	---	0.85	nm	RMS(σ)
Extinction Ratio	ER	9	---	---	dB	
Output Eye	Compliant with IEEE 802.3z					
Optical Rise Time	tr			0.26	ns	20% to 80% Values
Optical Fall Time	tf			0.26	ns	20% to 80% Values
Relative Intensity Noise	RIN			-117	dB/Hz	
Total Jitter	TJ			227	ps	
Coupled Power Ratio	CPR	9			dB	
Electrical						
Power Supply Current	Icc			120	mA	1
Data Input Current – Low	IIL	-350			μA	
Data Input Current – High	IIH			350	μA	
Differential Input Voltage	V _{IH} - V _{IL}	300			mV	
Data Input Voltage – Low	V _{IL} - V _{CC}	-2.0		-1.58	V	2
Data Input Voltage -- High	V _{IH} - V _{CC}	-1.1		-0.74	V	2

1. Maximum current is specified at Vcc=Maximum @ maximum temperature.
2. These inputs are compatible with 10K, 10KH and 100K ECL and LVPECL inputs.

Receiver Specifications (0°C < Topr < 70°C, 3.1V < Vcc < 3.5V)						
Parameter	Symbol	Min	Typ	Max	Units	Notes
Optical						
Sensitivity	---	---	---	-18	dBm	1
Maximum Input Power	Pin	0		---	dBm	
Signal Detect -- Asserted	Pa	---	---	-18	dBm	Transition: low to high
Signal Detect -- Deasserted	Pd	-30	---	---	dBm	Transition: high to low
Signal detect -- Hysteresis			3		dB	
Wavelength of Operation		770	---	860	nm	
Electrical						
Power Supply Current	Icc			100	mA	2
Data Output Voltage – Low	V _{OL} - V _{CC}	-2.0		-1.58	V	3
Data Output Voltage – High	V _{OH} - V _{CC}	-1.1		-0.74	V	3
Signal Detect Output Voltage -- Low	V _{OL} - V _{CC}	-2.0		-1.58	V	TRM-7100G
Signal Detect Output Voltage -- High	V _{OH} - V _{CC}	-1.1		-0.74	V	
Signal Detect Output Voltage -- Low	V _{SDL}			0.5	V	TRM-7100CG
Signal Detect Output Voltage -- High	V _{SDH}	2.0			V	

1. Minimum sensitivity and saturation levels at BER=1E-12 for a 2⁷-1 PRBS at ER=9 dB. For example, an OMA of 22μW is approximately equal to an average power of -18.4 dBm, average with an Extinction ratio of 9 dB.

2. The current excludes the output load current.
 3. These outputs are compatible with 10K, 10KH and 100K ECL and PECL outputs.

CONNECTION DIAGRAM

Receiver Signal Ground	1 (Rx GND)	○
Receiver Data Out	2 (RD+)	N/C
Receiver Data Out Bar	3 (RD-)	
Signal Detect	4 (SD)	
Receiver Power Supply	5 (Rx Vcc)	
Transmitter Power Supply	6 (Tx Vcc)	
Transmitter Data In Bar	7 (TD-)	
Transmitter Data In	8 (TD+)	N/C
Transmitter Signal Ground	9 (Tx GND)	○

TOP VIEW

PIN	Symbol	Notes
1	Rx GND	Directly connect this pin to the receiver ground plane
2	RD+	See recommended circuit schematic
3	RD-	See recommended circuit schematic
4	SD	Active high on this indicates a received optical signal
5	Rx Vcc	+3.3V dc power for the receiver section
6	Tx Vcc	+3.3V dc power for the transmitter section
7	TD-	See recommended circuit schematic
8	TD+	See recommended circuit schematic
9	Tx GND	Directly connect this pin to the transmitter ground plane

RECOMMENDED CIRCUIT SCHEMATIC

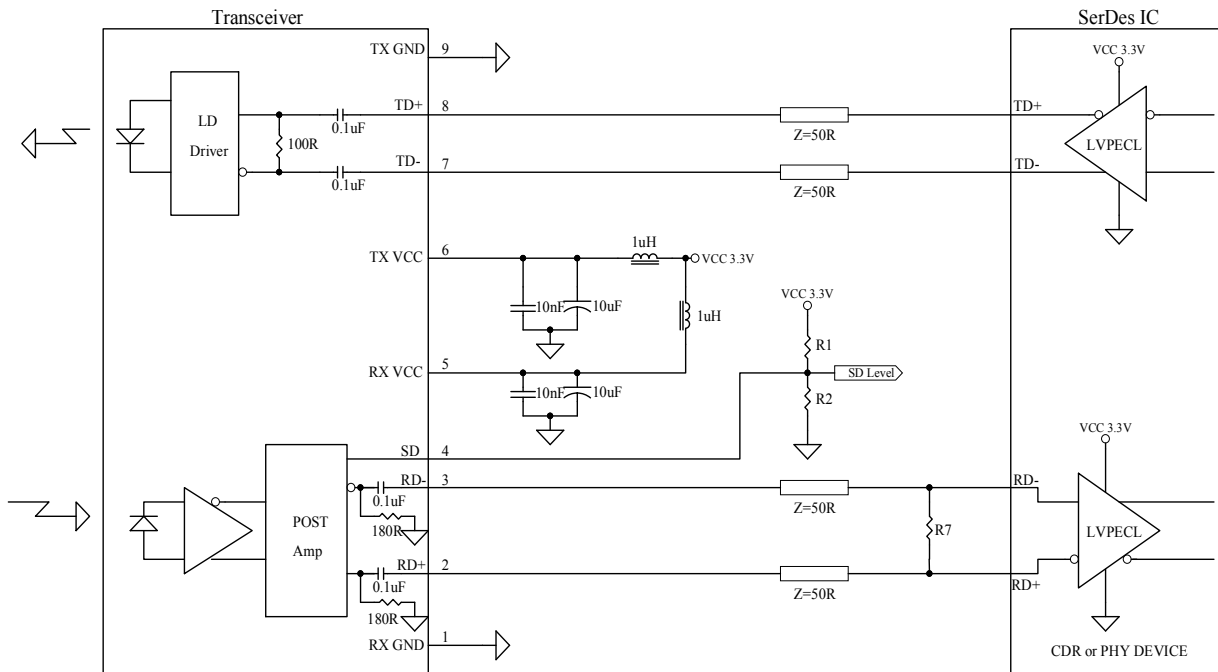

For TTL SD Level, R1=R2=N.C., R7=100 ohm

For PECL SD Level, R1=130 ohm, R2=82 ohm, R7=100 ohm

The split-load terminations for ECL signals need to be located at the input of devices receiving those ECL signals. The power supply filtering is required for good EMI performance. Use short tracks from the inductor L1/L2 to the module Rx Vcc and Tx Vcc. A GND plane under the module is required for good EMI and sensitivity performance.

PACKAGE DIAGRAM

Units in mm

1) SC Type

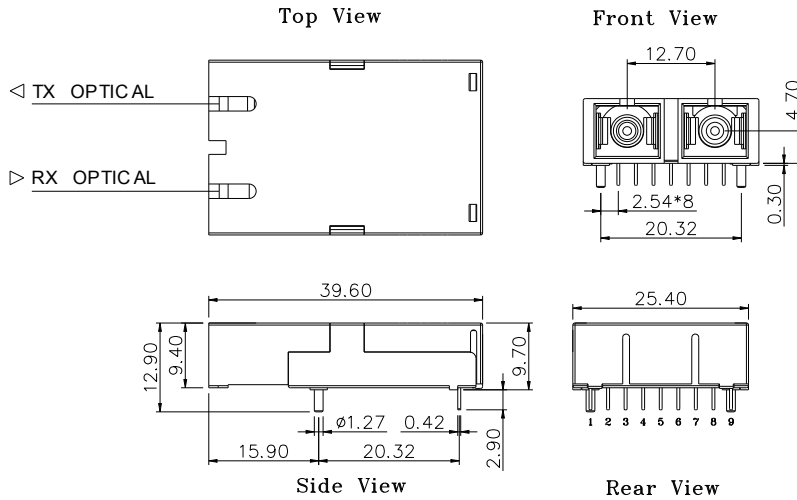

TRM-7100G / TRM-7100CG / TRM-7100AG / TRM-7100ACG

2) SC Type With Extended Shielding

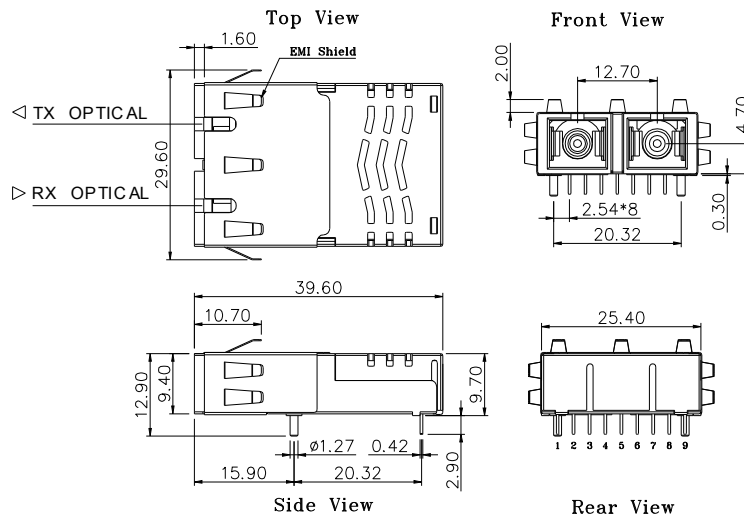

TRM-7100-EMG / TRM-7100C-EMG / TRM-7100A-EMG / TRM-7100AC-EMG

3) FC Type

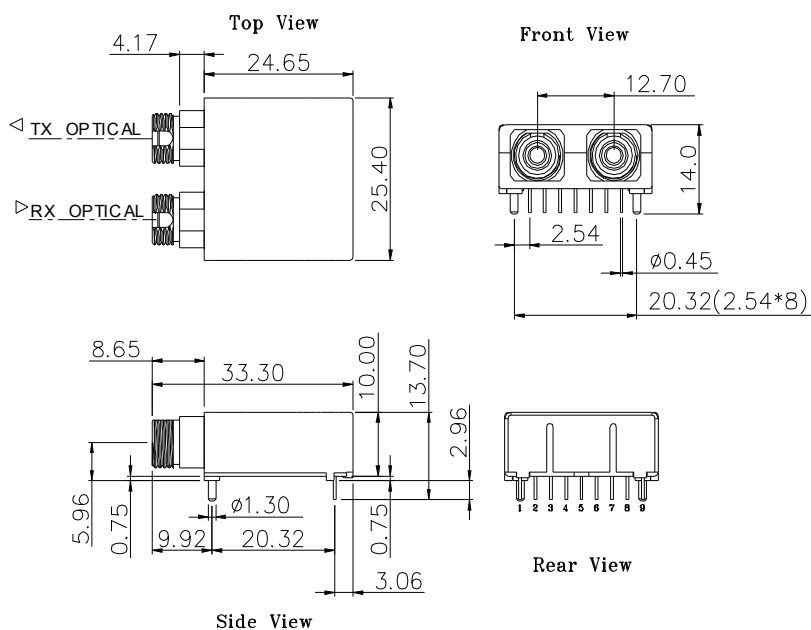

TRM-7100FG / TRM-7100CFG / TRM-7100AFG/ TRM-7100ACFG

Note: Specifications subject to change without notice.

REVISION HISTORY

Version	Subject	Release Date
3.0	Update Min. Operating Temperature of the I-Temp model from -20 to -40°C	2023/8/1