

TRSL-73120CG / TRSL-73120BCG / TRSL-73120ACG

(RoHS Compliant)

TRSL-73120G / TRSL-73120BG/ TRSL-73120AG

3.3V / 1550 nm / 1.25 Gbps SFF LC SINGLE-MODE TRANSCEIVER

FEATURES

- | Duplex LC Single Mode Transceiver
- | IEEE 802.3z 1000BASE-ZX Compliant
- | Fibre Channel 1X SM-LC-L FC-PI Compliant
- | Small Form Factor, RJ-45 size, 2X5 pin Package
- | 1550 nm DFB LD Transmitter
- | 32 dB Power Budget at Least
- | Distance up to 120 km
- | AC/AC Coupled Signal Input / Output
- | LVTTTL Transmitter Disable Input
- | LVTTTL Signal Detect Output :TRSL-73120CG
- | LVPECL Signal Detect Output :TRSL-73120G
- | Single +3.3 V Power Supply
- | 0 to 70°C Operating: TRSL-73120G
- | -10 to 85°C Operating: TRSL-73120BG
- | -40 to 85°C Operating: TRSL-73120AG
- | Wave Solderable and Aqueous Washable
- | Class 1 Laser International Safety Standard IEC-60825 Compliant

DESCRIPTION

The TRSL-73120CG series single mode transceivers is small form factor, low power, high performance module for bi-directional serial optical data communications such as IEEE 802.3z Gigabit Ethernet 1000BASE-ZX and Fiber Channel 1X SM-LC-L FC-PI. This module is designed for single mode fiber and operates at a nominal wavelength of 1550 nm. A guaranteed minimum optical link budget of 32 dB is offered which can correspond to a link distance of over 120 km (assuming worst case fiber loss of 0.22 dB/km). The transmitter section uses a multiple quantum well DFB laser and is a class 1 laser compliant according to International Safety Standard IEC-60825. The receiver section uses an integrated InGaAs detector preamplifier (IDP) mounted in an optical header and a limiting post-amplifier IC. A LVPECL logic interface simplifies interface to external circuitry.

APPLICATIONS

- | Gigabit Ethernet Switches and Routers
- | Fiber Channel Switch Infrastructure
- | Metro Edge Switching

LASER SAFETY

This single mode transceiver is a Class 1 laser product. It complies with IEC-60825 and FDA 21 CFR 1040.10 and 1040.11. The transceiver must be operated within the specified temperature and voltage limits. The optical ports of the module shall be terminated with an optical connector or with a dust plug.

ORDER INFORMATION

P/No.	Bit Rate (Gb/s)	1000 BASE	Distance (km)	Wavelength (nm)	Package	Temp. (°C)	TX Power (dBm)	RX Sens. (dBm)	RoHS Cmppliant
TRSL-73120CG	1.25/1.063		120	1550 DFB	2X5 LC	0 to 70	5 to 0	-32	Yes
TRSL-73120BCG	1.25/1.063		120	1550 DFB	2X5 LC	-10 to 85	5 to 0	-32	Yes
TRSL-73120ACG	1.25/1.063		120	1550 DFB	2X5 LC	-40 to 85	5 to 0	-32	Yes

Absolute Maximum Ratings					
Parameter	Symbol	Min	Max	Units	Notes
Storage Temperature	Tstg	-40	85	°C	
Operating Case Temperature	Topr	0	70	°C	TRSL-73120G TRSL-73120BG TRSL-73120AG Air flow 1m/sec
		-10	85		
		-40	85		
Soldering Temperature	---		260	°C	10 seconds on leads only
Power Supply Voltage	Vcc	0	4.5	V	
Input Voltage	---	GND	Vcc	V	
Output Current	Iout	0	30	mA	

Recommended Operating Conditions					
Parameter	Symbol	Min	Typ	Max	Units / Notes
Power Supply Voltage	Vcc	3.13	3.3	3.47	V
Operating Temperature	Topr	0		70	°C / TRSL-73120G
		-10		85	°C / TRSL-73120G

		-40		85	°C / TRSL-73120G Air flow 1m/sec
Data Rate		1000	1250		Mb/s
Power Supply Current	I _{cc}		200	280	mA

Transmitter Specifications (0°C < Topr < 70°C, 3.13V < Vcc < 3.47V)						
Parameter	Symbol	Min	Typ	Max	Units	Notes
Optical						
Optical Transmit Power	P _o	0	---	5	dBm	1
Output Center Wavelength	λ	1520		1580	nm	
Output Spectrum Width	Δλ	---	---	1	nm	-20 dB Width
Side Mode Suppression Ratio	SMSR	30			dB	
Extinction Ratio	E _R	9	---	---	dB	
Output Eye	Compliant with IEEE 802.3z					
Optical Rise Time	t _r			0.26	ns	20% to 80% Values
Optical Fall Time	t _f			0.26	ns	20% to 80% Values
Relative Intensity Noise	RIN			-120	dB/Hz	
Total Jitter	TJ			0.227	ns	2
Electrical						
Data Input Current – Low	I _{IL}	-350			μA	
Data Input Current – High	I _{IH}			350	μA	
Differential Input Voltage	V _{IH} - V _{IL}	300			mV	
Data Input Voltage – Low	V _{IL} - V _{CC}	-2.0		-1.58	V	3
Data Input Voltage -- High	V _{IH} - V _{CC}	-1.1		-0.74	V	3
Disable Input Voltage -- Low	V _{TDIS,L}	0		0.5	V	TX Output Enabled
Disable Input Voltage -- High	V _{TDIS,H}	V _{cc} - 1.3		V _{cc}	V	TX Output Disabled
Shut Off Time for TxDis	t _{DIS}			1	ms	

- Notes: 1. Output power is power coupled into a 9/125 μm single mode fiber.
 2. Measured with a 2⁷-1 PRBS.
 3. These inputs are compatible with 10K, 10KH and 100K ECL and PECL inputs.

Receiver Specifications (0°C < Topr < 70°C, 3.13V < Vcc < 3.47V)						
Parameter	Symbol	Min	Typ	Max	Units	Notes
Optical						
Sensitivity	---	---	---	-32	dBm	1
Maximum Input Power	P _{in}	-9		---	dBm	
Signal Detect -- Asserted	P _a	---	---	-32	dBm	Transition: low to high
Signal Detect -- Deasserted	P _d	-45	---	---	dBm	Transition: high to low
Signal detect -- Hysteresis		1.0	---		dB	
Wavelength of Operation		1100	---	1600	nm	
Electrical						
Data Output Voltage – Low	V _{OL} - V _{CC}	-2.0		-1.58	V	2
Data Output Voltage – High	V _{OH} - V _{CC}	-1.1		-0.74	V	2
Signal Detect Output Voltage -- Low	V _{OL}			0.5	V	TRSL-73120CG
Signal Detect Output Voltage -- High	V _{OH}	2.0			V	
Signal Detect Output Voltage -- Low	V _{OL} - V _{CC}	-2.0		-1.58	V	TRSL-73120G
Signal Detect Output Voltage -- High	V _{OH} - V _{CC}	-1.1		-0.74	V	

- Notes: 1. Minimum sensitivity and saturation levels at BER=1E-12 for a 2⁷-1 PRBS.
 2. These outputs are compatible with 10K, 10KH and 100K ECL and PECL outputs.

CONNECTION DIAGRAM



PIN	Symbol	Notes
1	V_{EEr}	Directly connect this pin to the receiver ground plane
2	V_{CCr}	+3.3V dc power for the receiver section
3	SD	Active high on this indicates a received optical signal.
4	RD-	Receiver Dataout Bar. See recommended circuit schematic
5	RD+	Receiver Dataout. See recommended circuit schematic
6	V_{CCt}	+3.3V dc power for the transmitter section
7	V_{EEt}	Directly connect this plan to the transmitter ground plane
8	TDis	Transmitter Disable. Connect this pin to +3.3V TTL logic "1" to disable module To enable module connect to TTL logic low "0"
9	TD+	Transmitter Data In. See recommended circuit schematic
10	TD-	Transmitter Data In Bar. See recommended circuit schematic
MS	MS	Mounting Studs. Connect to Chassis Ground

RECOMMENDED CIRCUIT SCHEMATIC

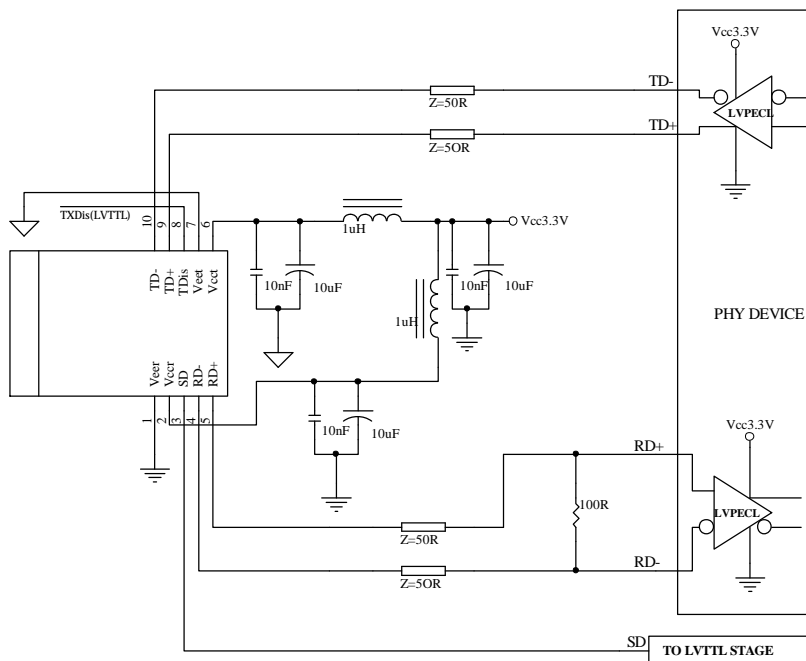

- Note: 1. TX input is terminated inside the module.
 2. 1000 Ω SD Output pull-down resistor required for TRSL-7XX0G / TRSL-7XX0AG (LVPECL SD Output).
 3. Veer and Veet are not internally connected to each other.
 4. 50 Ω line pattern and component placements on TD+/TD- and RD+/RD- lines shall be symmetrical for better impedance matching.

PACKAGE DIAGRAM

Units in mm

1) Standard Case

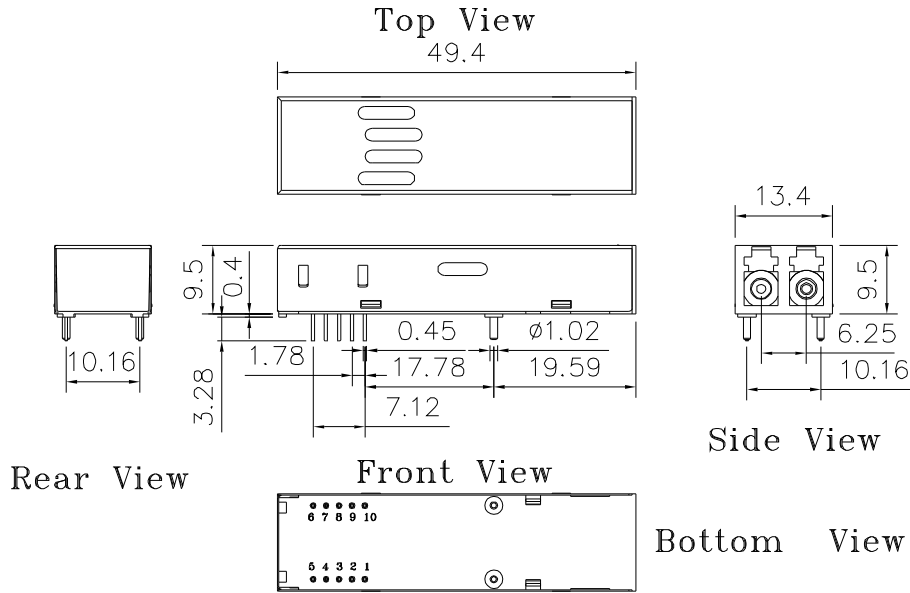

TRSL-73120G / TRSL-73120CG

2) Extended Case

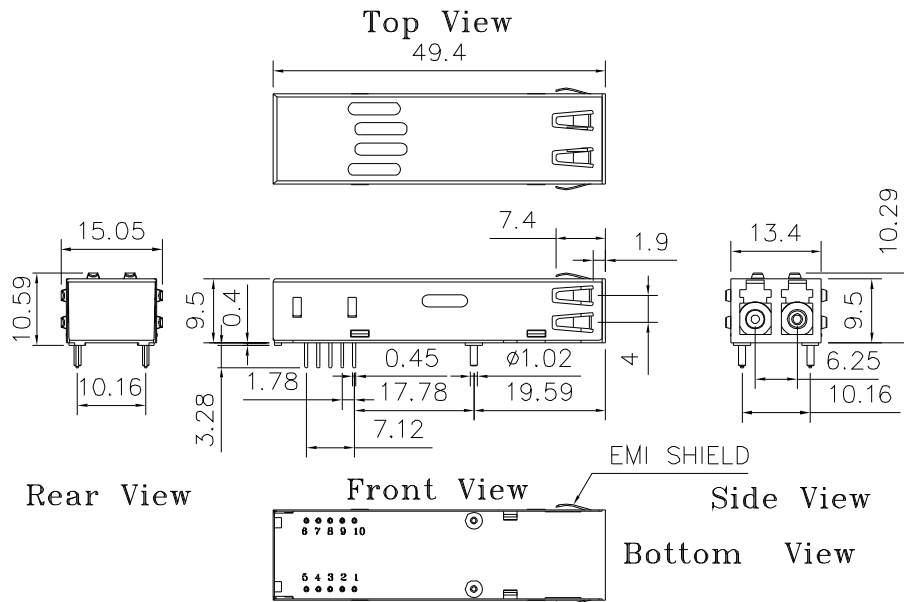

TRSL-73120EG / TRSL-73120CEG

Note: Specifications subject to change without notice.