

TRML-9100FG / TRML-9100FAG

3.3V / 850 nm / 2.5 Gbps **RoHS Compliant** SFF LC MULTI-MODE TRANSCEIVER

FEATURES

- | Duplex LC Multi-Mode Transceiver
- | Compliant with Fibre Channel FC-PH-2 for 200-M5-SN-1 and 200-M6-SN-1
- | Compliant with IEEE 802.3z 1000BASE-SX
- | Link Distance at 2.125 Gbd
150 m links with 62.5/125 µm MMF Cables
300 m links with 50/125 µm MMF Cables
- | Link Distance at 1.026 Gbd
300 m links with 62.5/125 µm MMF Cables
500 m links with 50/125 µm MMF Cables
- | Small Form Factor, RJ-45 size, 2X5 pin Package
- | AC/AC Coupled Signal Input / Output
- | LVTTTL Transmitter Disable Input
- | LVTTTL Signal Detection Output
- | Single +3.3 V Power Supply
- | RoHS Compliant
- | 0 to 70°C Operating: TRML-9100FG
- | -20 to 85°C Operating: TRML-9100FAG
- | Wave Solderable and Aqueous Washable
- | Class 1 Laser International Safety Standard IEC-60825 Compliant

DESCRIPTION

The TRML-9100FG series multi-mode transceivers is small form factor, low power, high performance module for bi-directional serial optical data communications such as Fibre Channel FC-PH-2 for 200-M5-SN-1 and 200-M6-SN-1 and Gigabit Ethernet IEEE 802.3z 1000BASE-SX. This module is designed for multi-mode fiber and operates at a nominal wavelength of 850 nm. The transmitter section uses a multiple quantum well 850 nm VCSEL and is a class 1 laser compliant according to International Safety Standard IEC-60825. The receiver section uses an integrated GaAs detector preamplifier (IDP) mounted in an optical header and a limiting post-amplifier IC. A PECL logic interface simplifies interface to external circuitry.

LASER SAFETY

This multi-mode transceiver is a Class 1 laser product. It complies with IEC-60825 and FDA 21 CFR 1040.10 and 1040.11. The transceiver must be operated within the specified temperature and voltage limits. The optical ports of the module shall be terminated with an optical connector or with a dust plug.

APPLICATIONS

- | SONET/SDH Equipment Interconnect
- | Gigabit Ethernet 1.25 Gb/s Links

ORDER INFORMATION

P/No.	Bit Rate (Gb/s)	FC-PI	Distance (m)	Wavelength (nm)	Package	Temp. (°C)	TX Power (dBm)	RX Sens. (dBm)	RoHS Compliant
TRML-9100FG	2.125/1.063	200/100	150/300*	850	2X5 LC	0 to 70	-4 to -9	-15	Yes
TRML-9100FAG	2.125/1.063	200/100	150/300*	850	2X5 LC	-20 to 85	-4 to -9	-15	Yes

Note: 150 m links with 62.5/125 µm MMF Cables and 300 m links with 62.5/125 µm MMF Cables.

Absolute Maximum Ratings					
Parameter	Symbol	Min	Max	Units	Notes
Storage Temperature	Tstg	-40	85	°C	
Operating Temperature	Topr	0	70	°C	TRML-9100FG
		-20	85		TRML-9100FAG
Soldering Temperature	---		260	°C	10 seconds on leads only
Power Supply Voltage	Vcc	0	4.5	V	
Input Voltage	---	GND	Vcc	V	

Recommended Operating Conditions					
Parameter	Symbol	Min	Typ	Max	Units / Notes
Power Supply Voltage	Vcc	3.13	3.3	3.47	V
Operating Temperature	Topr	0		70	°C / TRML-9100FG
		-20		85	°C / TRML-9100FAG
Data Rate		1	2.125		Gb/s
Power Supply Current	Icc		180	240	mA

Transmitter Specifications (0°C < Topr < 70°C, 3.13V < Vcc < 3.47V)						
Parameter	Symbol	Min	Typ	Max	Units	Notes
Optical						
Optical Transmit Power	Po	-9	---	-4	dBm	1
Output Center Wavelength	λ	830	850	860	nm	
Output Spectrum Width	$\Delta\lambda$	---	---	0.85	nm	RMS (σ)
Optical Modulation Amplitude	OMA	196			μ W	2
Extinction Ratio	ER		9	---	dB	
Output Eye	Compliant with IEEE 802.3z					
Optical Rise Time	t _r			150	ps	20% to 80%
Optical Fall Time	t _f			150	ps	20% to 80%
Relative Intensity Noise	RIN			-117	dB/Hz	
Electrical						
Data Input Current – Low	I _{IL}	-350			μ A	
Data Input Current – High	I _{IH}			350	μ A	
Differential Input Voltage	V _{IH} - V _{IL}	300			mV	
Data Input Voltage – Low	V _{IL} - V _{CC}	-2.0		-1.58	V	3
Data Input Voltage -- High	V _{IH} - V _{CC}	-1.1		-0.74	V	3
Disable Input Voltage -- Low	V _{TDIS,L}	0		0.5	V	TX Output Enabled
Disable Input Voltage -- High	V _{TDIS,H}	V _{CC} - 1.3		V _{CC}	V	TX Output Disabled
Shut Off Time for TxDis	t _{DIS}			1	ms	

- Notes: 1. Output power is power coupled into a 62.5/125 μ m MM fiber.
 2. An OMA of 196 μ W is approximately equal to an average power of -9 dBm assuming an Extinction Ratio of 9 dB.
 3. These inputs are compatible with 10K, 10KH and 100K ECL and PECL inputs.

Receiver Specifications (0°C < Topr < 70°C, 3.13V < Vcc < 3.47V)						
Parameter	Symbol	Min	Typ	Max	Units	Notes
Optical						
Sensitivity	---	---	---	-15	dBm	1
Maximum Input Power	Pin	0		---	dBm	
Signal Detect -- Asserted	Pa	---	---	-15	dBm	Transition: low to high
Signal Detect -- Deasserted	Pd	-31	---	---	dBm	Transition: high to low
Signal detect -- Hysteresis		1.0	---		dB	
Wavelength of Operation		1100	---	1600	nm	
Electrical						
Data Output Voltage – Low	V _{OL} - V _{CC}	-2.0		-1.58	V	2
Data Output Voltage – High	V _{OH} - V _{CC}	-1.1		-0.74	V	2
Signal Detect Output Voltage -- Low	V _{OL}			0.5	V	
Signal Detect Output Voltage -- High	V _{OH}	2.0			V	

- Notes: 1. Minimum sensitivity and saturation levels at BER=1E-12 for a 2⁷-1 PRBS.
 2. These outputs are compatible with 10K, 10KH and 100K ECL and PECL outputs.

CONNECTION DIAGRAM

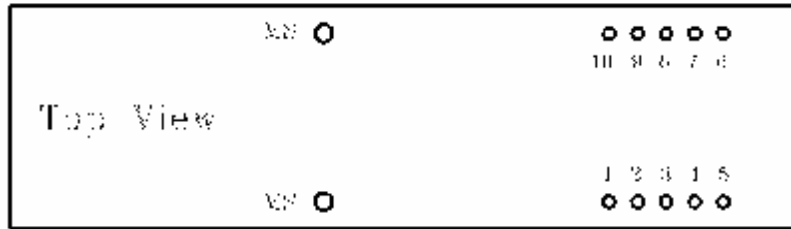

PIN	Symbol	Notes
1	V _{EEt}	Directly connect this pin to the receiver ground plane
2	V _{CC r}	+3.3V dc power for the receiver section
3	SD	Active high on this indicates a received optical signal.
4	RD-	Receiver Dataout Bar. See recommended circuit schematic
5	RD+	Receiver Dataout. See recommended circuit schematic
6	V _{CC t}	+3.3V dc power for the transmitter section
7	V _{EEt}	Directly connect this plan to the transmitter ground plane
8	TDis	Transmitter Disable. Connect this pin to +3.3V TTL logic "1" to disable module To enable module connect to TTL logic low "0"
9	TD+	Transmitter Data In. See recommended circuit schematic
10	TD-	Transmitter Data In Bar. See recommended circuit schematic
MS	MS	Mounting Studs. Connect to Chassis Ground

RECOMMENDED CIRCUIT SCHEMATIC

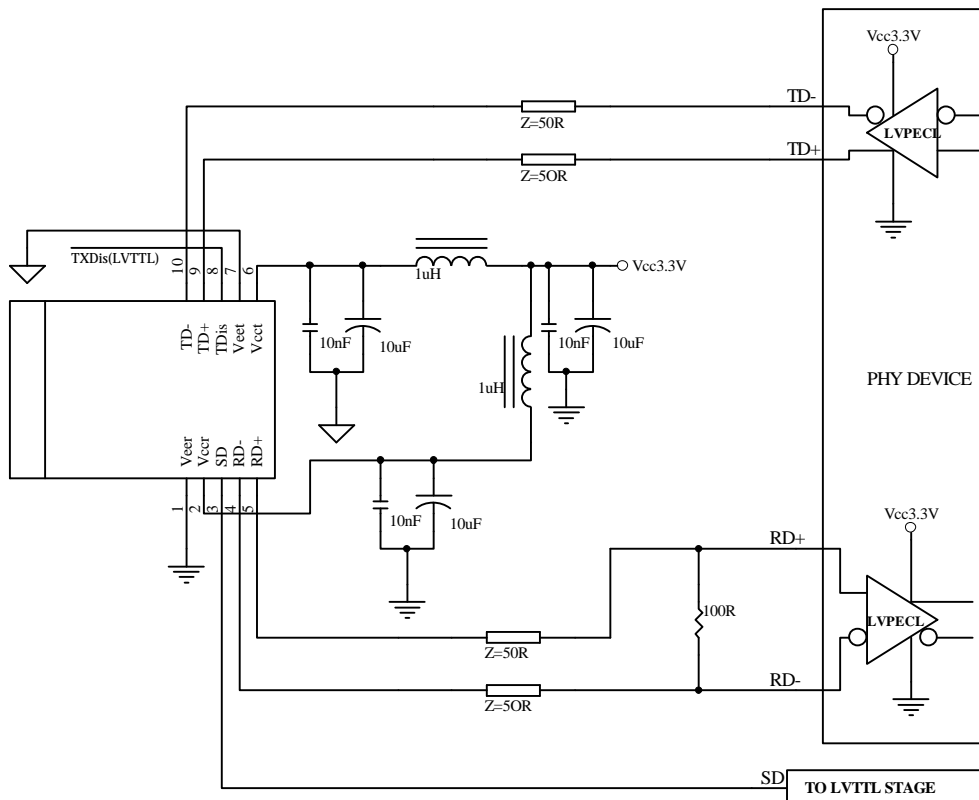

- Note: 1. Veer and Veet are not internally connected to each other.
 2. 50 Ω line pattern and component placements on TD+/TD- and RD+/RD- lines shall be symmetrical for better impedance matching.

PACKAGE DIAGRAM

Units in mm

1) Standard Case

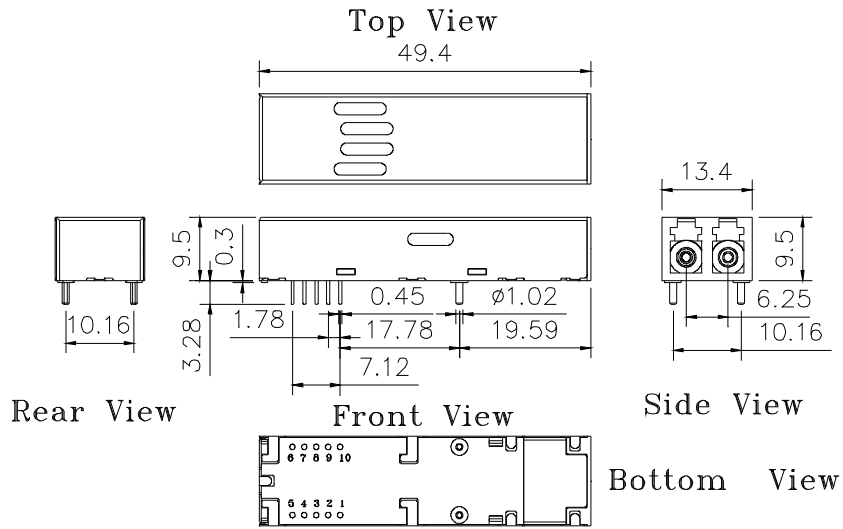

TRML-9100FG / TRML-9100FAG

2) Extended Case

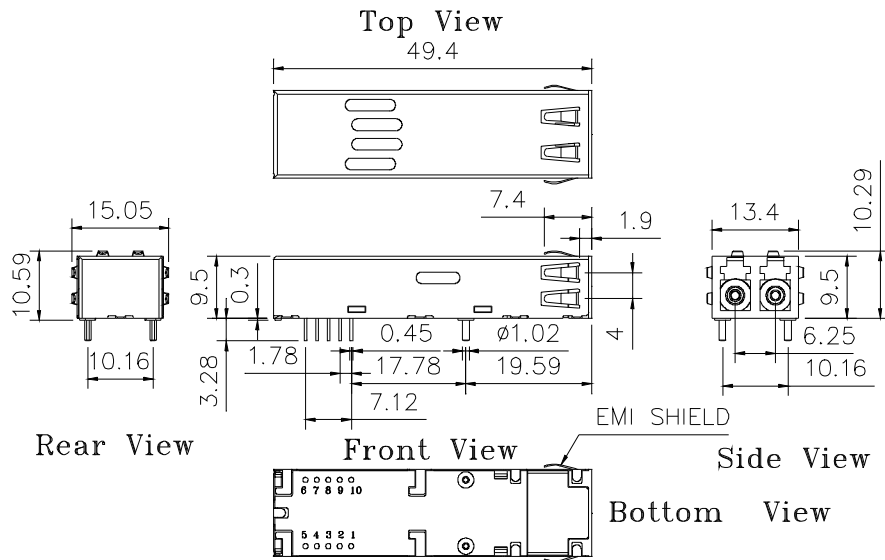

TRML-9100FEG / TRML-9100FAEG

Note: Specifications subject to change without notice.