

SPS-4341W-DXXG**(RoHS Compliant)****8.5 Gbps/ 100GHz DWDM / 40 km Digital Diagnostic LC SFP+ SINGLE-MODE TRANSCEIVER****FEATURES**

- | Up to 8.5 Gbps Bi-directional Data Links
- | Complaint to SFP+ MSA
- | Compliance with Fibre Channel FC-PI-4 800-SM-LC-L
- | Compliant with 4G and, 2G Fibre Channel
- | **Temperature-stabilized DWDM EML Transmitter**
- | **100 GHz ITU Grid, C Band**
- | **Distance up to 40 km**
- | SFF-8472 Digital Diagnostic Function
- | AC/AC Coupling according to MSA
- | Single +3.3 V Power Supply
- | RoHS 6/6 Compliant
- | 0 to 70°C Operating
- | Class 1 Laser International Safety Standard IEC-60825 Compliant

APPLICATIONS

- | Multi-rate 8x / 4x / 2x Fibre Channel

DESCRIPTION

The SPS-4341W-DXXG series single mode transceiver is small form factor pluggable module for bi-directional serial optical data communications such as 8x/4x/2x Fibre Channel.

It is with the SFP 20-pin connector to allow hot plug capability. Digital diagnostic functions are available via an I²C. This module is designed for single mode fiber and operates at a nominal wavelength of 100GHz ITU Grid, C Band DWDM wavelength. A guaranteed minimum optical link budget of 14 dB is offered. The transmitter section consists of a temperature-stabilized DWDM electrical-modulated laser (EML), driver and signal conditioner. The receiver section uses an integrated InGaAs detector preamplifier (IDP) mounted in an optical header and a limiting post-amplifier IC.

LASER SAFETY

This single mode transceiver is a Class 1 laser product. It complies with IEC-60825 and FDA 21 CFR 1040.10 and 1040.11. The transceiver must be operated within the specified temperature and voltage limits. The optical ports of the module shall be terminated with an optical connector or with a dust plug.

ORDER INFORMATION

P/No.	Bit Rate (Gb/s)	FC-PI	Power Budget (dB)	Spacing (GHz)	Wavelength (nm)	Package	Temp. (°C)	RoHS Compliant
SPS-4341W-DXXG	8 / 4 / 2	FC-PI-4	> 14	100	DWDM*	SFP+ with DMI	0 to 70	Yes

*: XX: 100GHz ITU Grid wavelength (Please see below)

Channel #	Product code	Frequency (THz)	Center Wavelength (nm)	Label
21	SPS-4341W-D21G	192.1	1560.61	D21
22	SPS-4341W-D22G	192.2	1559.79	D22
23	SPS-4341W-D23G	192.3	1558.98	D23
24	SPS-4341W-D24G	192.4	1558.17	D24
25	SPS-4341W-D25G	192.5	1557.36	D25
26	SPS-4341W-D26G	192.6	1556.55	D26
27	SPS-4341W-D27G	192.7	1555.75	D27
28	SPS-4341W-D28G	192.8	1554.94	D28
29	SPS-4341W-D29G	192.9	1554.13	D29
30	SPS-4341W-D30G	193.0	1553.33	D30
31	SPS-4341W-D31G	193.1	1552.52	D31
32	SPS-4341W-D32G	193.2	1551.72	D32
33	SPS-4341W-D33G	193.3	1550.92	D33
34	SPS-4341W-D34G	193.4	1550.12	D34
35	SPS-4341W-D35G	193.5	1549.32	D35
36	SPS-4341W-D36G	193.6	1548.51	D36
37	SPS-4341W-D37G	193.7	1547.72	D37
38	SPS-4341W-D38G	193.8	1546.92	D38
39	SPS-4341W-D39G	193.9	1546.12	D39
40	SPS-4341W-D40G	194.0	1545.32	D40
41	SPS-4341W-D41G	194.1	1544.53	D41
42	SPS-4341W-D42G	194.2	1543.73	D42
43	SPS-4341W-D43G	194.3	1542.94	D43
44	SPS-4341W-D44G	194.4	1542.14	D44
45	SPS-4341W-D45G	194.5	1541.35	D45
46	SPS-4341W-D46G	194.6	1540.56	D46
47	SPS-4341W-D47G	194.7	1539.77	D47
48	SPS-4341W-D48G	194.8	1538.98	D48
49	SPS-4341W-D49G	194.9	1538.19	D49
50	SPS-4341W-D50G	195.0	1537.40	D50
51	SPS-4341W-D51G	195.1	1536.61	D51
52	SPS-4341W-D52G	195.2	1535.82	D52
53	SPS-4341W-D53G	195.3	1535.04	D53
54	SPS-4341W-D54G	195.4	1534.25	D54
55	SPS-4341W-D55G	195.5	1533.47	D55
56	SPS-4341W-D56G	195.6	1532.68	D56
57	SPS-4341W-D57G	195.7	1531.90	D57
58	SPS-4341W-D58G	195.8	1531.12	D58
59	SPS-4341W-D59G	195.9	1530.33	D59
60	SPS-4341W-D60G	196.0	1529.55	D60

Absolute Maximum Ratings					
Parameter	Symbol	Min	Max	Units	Notes
Storage Temperature	Tstg	-40	85	°C	
Operating Case Temperature	Topr	0	70	°C	
Power Supply Voltage	Vcc	-0.5	3.6	V	

Recommended Operating Conditions					
Parameter	Symbol	Min	Typ	Max	Units / Notes
Power Supply Voltage	Vcc	3.13	3.3	3.47	V
Operating Case Temperature	Topr	0		70	°C
Power Supply Current	I _{CC(TX+RX)}		330	500	mA
Data Rate		2.125	8.5		Gb/s

Transmitter Optical Specifications (0°C < Topr < 70°C, 3.13V < Vcc < 3.47V)						
Parameter	Symbol	Min	Typ	Max	Units	Notes
Average Launch Power	P _{O, AVG}	-2		2	dBm	1
Extinction Ratio	ER	8.2			dB	
Center Wavelength Spacing			100		GHz	2
Transmitter Center Wavelength -- over life time	λ _c	X-100	X	X+100	pm	3
Output Spectrum Width	Δλ	---		1	nm	-20 dB width
Side Mode Suppression Ratio	SMSR	30			dB	
Transmitter and Dispersion Penalty @ 800 ps/nm	TDP			2	dB	
Relative Intensity Noise	RIN			-130	dB/Hz	
Average Launch Power of OFF Transmitter				-30	dBm	

1. Output power is power coupled into a 9/125 μm single-mode fiber.
2. Corresponds to approximately 0.8 nm.
3. X = specified ITU Grid wavelength.

Receiver Optical Specifications (0°C < Topr < 70°C, 3.13V < Vcc < 3.47V)						
Parameter	Symbol	Min	Typ	Max	Units	Notes
Sensitivity				-16	dBm	4
Receiver Overload	P _{MAX}	-1	---		dBm	
LOS -- Deasserted	LOS _D	---	---	-16	dBm	Transition: low to high
LOS -- Asserted	LOS _A	-26	---	---	dBm	Transition: high to low
Wavelength of Operation	λ _c	1480		1580	nm	

4. Measured with average power; BER < 10⁻¹² and PRBS 2⁷-1.

Electrical Characteristics						
Parameter	Symbol	Min	Typ	Max	Units	Notes
High-Speed Signal (CML) Interface Specification						
Input Data Rate		2.125	8.5		Gb/s	
Differential Input Impedance	R _{in}		100		Ω	
Differential Data Input Amplitude		150		1200	mV _{pp}	Internally AC coupled
Output Data Rate		2.125	8.5		Gb/s	
Differential Output Impedance	R _{out}		100		Ω	
Differential Data Output Amplitude		350	600	700	mV _{pp}	Internally AC coupled
Low-Speed Signal (LVTTTL) Interface Specification						
Input High Voltage		2.0		Vcc+0.3	V	

Input Low Voltage		GND		0.8	V	
Output High Voltage		2.4		Vcc	V	
Output Low Voltage		GND		0.5	V	

CONNECTION DIAGRAM

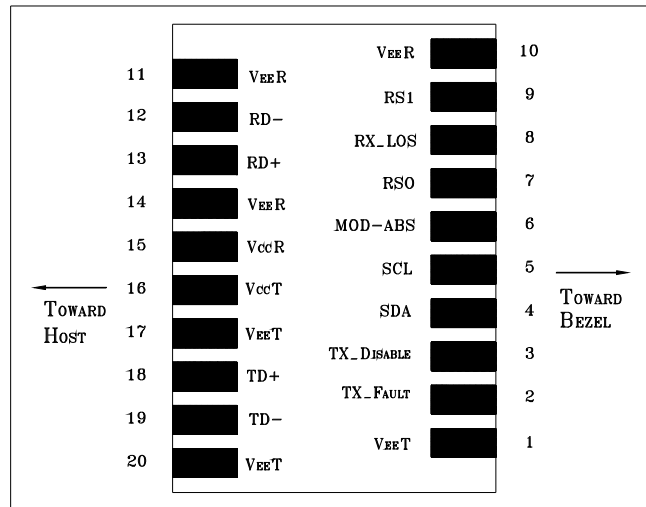

PIN	Signal Name	Description	PIN	Signal Name	Description
1	V _{EE} T	Transmitter Signal Ground	11	V _{EE} R	Receiver Signal Ground
2	TX_Fault	Transmitter Fault Indication. Logic "1" Output = Laser Fault. Logic "0" Output = Normal Operation	12	RD-	Inverse Receiver Data Out
3	TX_Disable	Logic "1" Input (or no connection) = Laser off, Logic "0" = Laser on.	13	RD+	Receiver Data Out
4	SDA	Modulation Definition 2 – Two wires serial ID Interface	14	V _{EE} R	Receiver Signal Ground
5	SDL	Modulation Definition 1 – Two wires serial ID Interface	15	V _{CC} R	Receiver Power – 3.3V±5%
6	MOD-ABS	Modulation Definition 0 – Ground in Module	16	V _{CC} T	Transmitter Power – 3.3V±5%
7	RS0	RX Rate Select (LVTTL). This pin has an internal 30k pulldown to ground. A signal on this pin will not affect module performance.	17	V _{EE} T	Transmitter Signal Ground
8	RX_LOS	Loss of Signal Out (OC).	18	TD+	Transmitter Data In
9	RS1	TX Rate Select (LVTTL). This pin has an internal 30k pulldown to ground. A signal on this pin will not affect module performance.	19	TD-	Inverse Transmitter Data In
10	V _{EE} R	Receiver Signal Ground	20	V _{EE} T	Transmitter Signal Ground

MODULE DEFINITION

Module Definition	PIN 4	PIN 5	PIN 6	Interpretation by Host
4	SDA	SCL	MOD-ABS	Serial module definition protocol

Module Definition 4 specifies a serial definition protocol. For this definition, upon power up, SDA and SDL appear as no connector (NC) and MOD-ABS is TTL LOW. When the host system detects this condition, it activates the serial protocol. The protocol uses the 2-wire serial CMOS E²PROM protocol of the ATMEL AT24C01A/02/04 family of components.

RECOMMENDED CIRCUIT SCHEMATIC

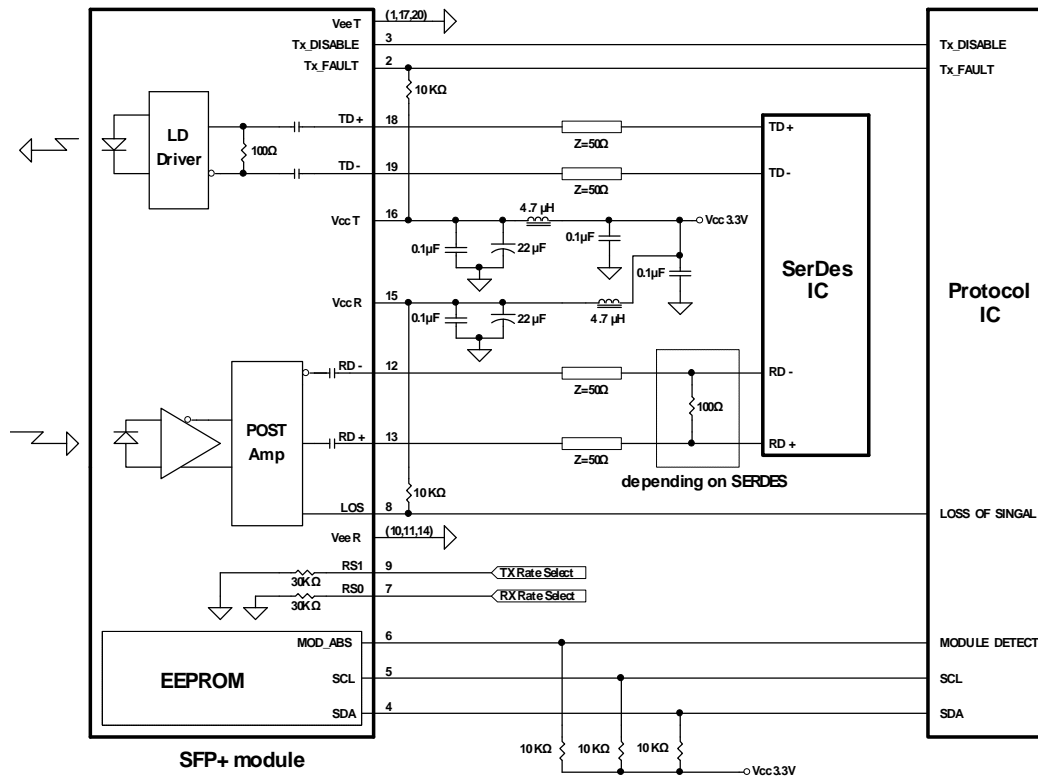

PACKAGE DIAGRAM

Units in mm

Top View

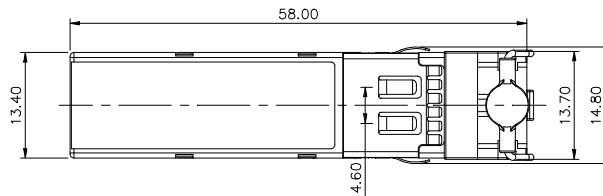

Front View

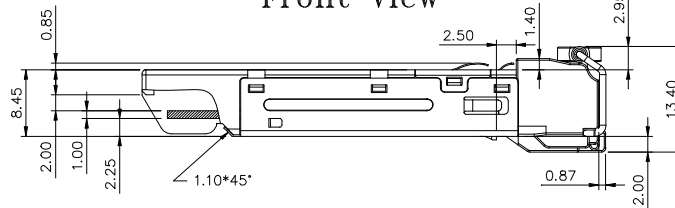

LATCH COLOR
Red

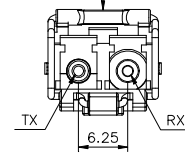

Side View

Bottom View

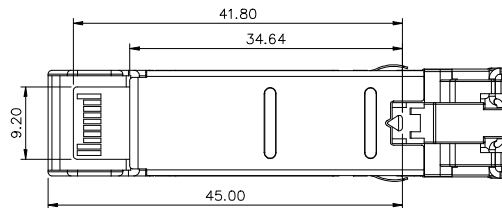

REVISION HISTORY

Version	Subject	Release Date
1.0	Initial datasheet	2010/4/1
2.0	Update Transmitter power to -2 to +2 dBm	2010/12/1

Note: Specifications subject to change without notice.