

SPS-2110WG / SPS-2110BWG / SPS-2110AWG

(RoHS Compliant)

10 Gb/s / 10 km / 1310 nm Digital Diagnostic SFP+ LC SINGLE-MODE TRANSCEIVER

FEATURES

- | Up to 10.5 Gb/s Bi-directional Data Links
- | Compliant with SFP+ MSA
- | Compliant to IEEE 802.3ae 10GBASE-LR
- | Compliant to IEEE 802.3ae 10GBASE-LW
- | SFF-8472 Digital Diagnostic Function
- | 1310 nm DFB LD Transmitter
- | AC/AC Coupling according to MSA
- | Distance up to 10 km at SM Fiber
- | Single +3.3 V Power Supply
- | RoHS 6/6 Compliant
- | 0 to 70°C Operating: SPS-2110WG
- | -10 to 85°C Operating: SPS-2110BWG
- | -40 to 85°C Operating: SPS-2110AWG
- | Class 1 Laser International Safety Standard IEC-60825 Compliant

APPLICATIONS

- | High-speed Storage Area Networks
- | Computer Cluster Cross-connect
- | Custom High-speed Data Pipes

DESCRIPTION

The SPS-2110WG series single mode transceiver is small form factor pluggable module for bi-directional serial optical data communications such as IEEE 802.3ae 10GBASE-LR/LW. It is with the SFP+ 20-pin connector to allow hot plug capability. Digital diagnostic functions are available via an I²C. This module is designed for single mode fiber and operates at a nominal wavelength of 1310 nm. The transmitter section uses a 1310 nm multiple quantum well DFB laser and is a class 1 laser compliant according to International Safety Standard IEC-60825. The receiver section uses an integrated InGaAs detector preamplifier (IDP) mounted in an optical header and a limiting post-amplifier IC.

LASER SAFETY

This single mode transceiver is a Class 1 laser product. It complies with IEC-60825 and FDA 21 CFR 1040.10 and 1040.11. The transceiver must be operated within the specified temperature and voltage limits. The optical ports of the module shall be terminated with an optical connector or with a dust plug.

ORDER INFORMATION

P/No.	Bit Rate (Gb/s)	10GBASE	Distance (km)	Wavelength (nm)	Package	Temp. (°C)	RoHS Compliant
SPS-2110WG	10.3	LR / LW	10	1310 DFB	SFP+ with DMI	0 to 70	Yes
SPS-2110BWG	10.3	LR / LW	10	1310 DFB	SFP+ with DMI	-10 to 85	Yes
SPS-2110AWG	10.3	LR / LW	10	1310 DFB	SFP+ with DMI	-40 to 85	Yes

Absolute Maximum Ratings

Parameter	Symbol	Min	Max	Units	Notes
Storage Temperature	T _{stg}	-40	85	°C	
Operating Case Temperature	T _{opr}	0	70	°C	SPS-2110WG
		-10	85		SPS-2110BWG
		-40	85		SPS-2110AWG
Power Supply Voltage	V _{cc}	-0.5	3.6	V	

Recommended Operating Conditions

Parameter	Symbol	Min	Typ	Max	Units / Notes
Power Supply Voltage	V _{cc}	3.13	3.3	3.47	V
Operating Case Temperature	T _{opr}	0		70	°C / SPS-2110WG
		-10		85	°C / SPS-2110BWG
		-40		85	°C / SPS-2110AWG
Power Supply Current	I _{CC(TX+RX)}		260	330	mA
Data Rate			10.3125	10.5	Gb/s

Transmitter Optical Specifications (0°C < T _{opr} < 70°C, 3.13V < V _{cc} < 3.47V)						
Parameter	Symbol	Min	Typ	Max	Units	Notes
Average Launch Power	P _{O, Avg}	-8		0.5	dBm	1
Optical Modulation Amplitude	P _{O, OMA}	-5.2			dBm	
Output Center Wavelength	λ _c	1270	1310	1355	nm	
Output Spectrum Width	σ _λ			1	nm	-20 dB width
Side Mode Suppression Ratio	SMSR	30			dB	
Extinction Ratio	ER	3.5				
Relative Intensity Noise	RIN			-128	dB/Hz	
Average Launch Power of OFF Transmitter				-30	dBm	

1. Output power is power coupled into a 9/125 μm single-mode fiber.

Receiver Optical Specifications (0°C < T _{opr} < 70°C, 3.13V < V _{cc} < 3.47V)						
Parameter	Symbol	Min	Typ	Max	Units	Notes
Sensitivity	Sen1			-14.4	dBm	2, average received power
Sensitivity in OMA	Sen1			-12.6	dBm	2
Stress Sensitivity in OMA	Sen2		---	-10.3	dBm	3
Receiver Overload	P _{MAX}	0.5	---		dBm	
LOS -- Deasserted	LOS _D	---	---	-18	dBm	Transition: low to high
LOS -- Asserted	LOS _A	-30	---	---	dBm	Transition: high to low
Wavelength of Operation	λ _c	1260		1565	nm	
Optical Return Loss	ORL			-12	dB	

2. Measured with worst ER; BER < 10⁻¹² and PRBS 2³¹-1 at 10.3125 Gb/s..

3. Per IEEE 802.3ae. Equivalent to -13.3 dBm average power at Infinite ER.

Electrical Characteristics						
Parameter	Symbol	Min	Typ	Max	Units	Notes
High-Speed Signal (CML) Interface Specification						
Input Data Rate			10.3125	10.5	Gb/s	
Differential Input Impedance	R _{in}		100		Ω	
Differential Data Input Amplitude		150		1200	mV _{pp}	Internally AC coupled
Output Data Rate			10.3125	10.5	Gb/s	
Differential Output Impedance	R _{out}		100		Ω	
Differential Data Output Amplitude		400	600	700	mV _{pp}	Internally AC coupled
Low-Speed Signal (LVTTTL) Interface Specification						
Input High Voltage		2.0		V _{cc} +0.3	V	
Input Low Voltage		GND		0.8	V	
Output High Voltage		2.4		V _{cc}	V	
Output Low Voltage		GND		0.5	V	

CONNECTION DIAGRAM

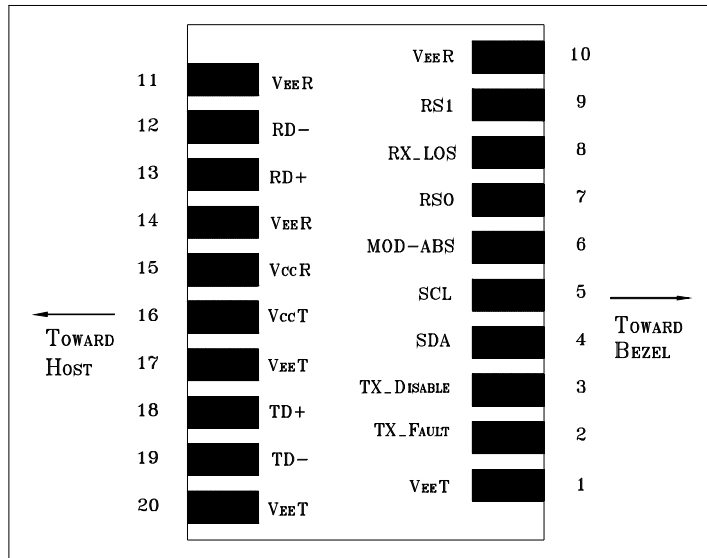

PIN	Signal Name	Description	PIN	Signal Name	Description
1	V _{EE} T	Transmitter Signal Ground	11	V _{EE} R	Receiver Signal Ground
2	TX_Fault	Transmitter Fault Indication. Logic "1" Output = Laser Fault. Logic "0" Output = Normal Operation	12	RD-	Inverse Receiver Data Out
3	TX_Disable	Logic "1" Input (or no connection) = Laser off, Logic "0" = Laser on.	13	RD+	Receiver Data Out
4	SDA	Modulation Definition 2 – Two wires serial ID Interface	14	V _{EE} R	Receiver Signal Ground
5	SDL	Modulation Definition 1 – Two wires serial ID Interface	15	V _{CC} R	Receiver Power – 3.3V±5%
6	MOD-ABS	Modulation Definition 0 – Ground in Module	16	V _{CC} T	Transmitter Power – 3.3V±5%
7	RS0	RX Rate Select (LVTTTL). This pin has an internal 30k pulldown to ground. A signal on this pin will not affect module performance.	17	V _{EE} T	Transmitter Signal Ground
8	RX_LOS	Loss of Signal Out (OC).	18	TD+	Transmitter Data In
9	RS1	TX Rate Select (LVTTTL). This pin has an internal 30k pulldown to ground. A signal on this pin will not affect module performance.	19	TD-	Inverse Transmitter Data In
10	V _{EE} R	Receiver Signal Ground	20	V _{EE} T	Transmitter Signal Ground

MODULE DEFINITION

Module Definition	PIN 4	PIN 5	PIN 6	Interpretation by Host
4	SDA	SCL	MOD-ABS	Serial module definition protocol

Module Definition 4 specifies a serial definition protocol. For this definition, upon power up, SDA and SDL appear as no connector (NC) and MOD-ABS is TTL LOW. When the host system detects this condition, it activates the serial protocol. The protocol uses the 2-wire serial CMOS E²PROM protocol of the ATMEL AT24C01A/02/04 family of components.

RECOMMENDED CIRCUIT SCHEMATIC

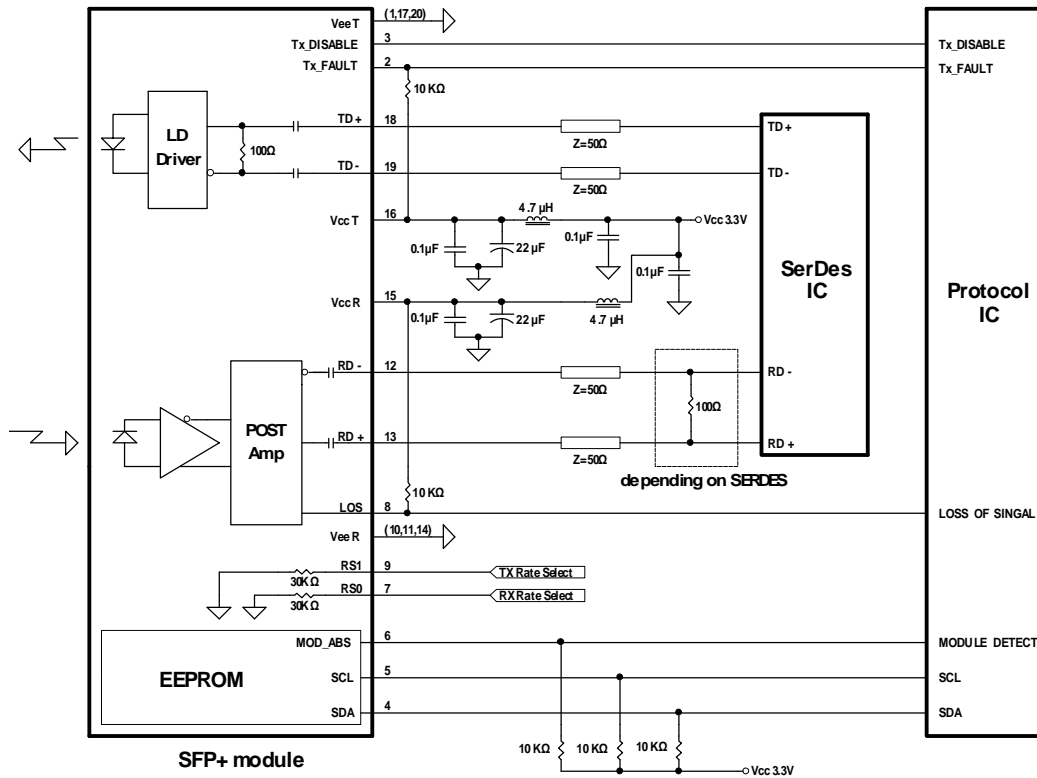

PACKAGE DIAGRAM

Units in mm

Top View

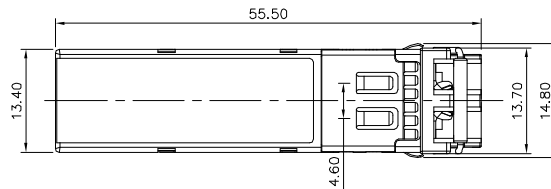

Front View

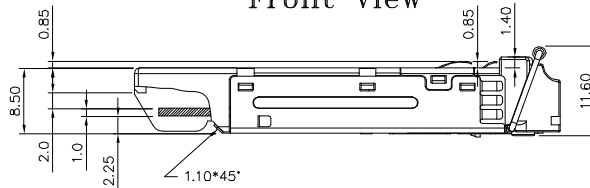

LATCH COLOR
BLUE: SM

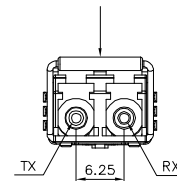

Side View

Bottom View

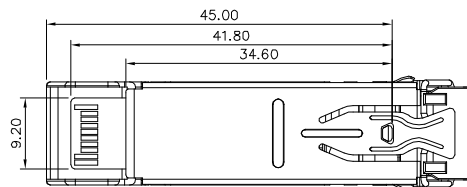

Note: Specifications subject to change without notice.

REVISION HISTORY

Version	Subject	Release Date
1.0	Initial datasheet	2007/10/1
2.0	Add SPS-2110AWG for -40 to 85°C	2007/12/1
