SPM-2100WG / SPM-2100BWG / SPM-2100AWG (RoHS Compliant)
3.3V / 850 nm / 10.3 Gb/s Digital Diagnostic SFP+ LC Multi-Mode TRANSCEIVER

FEATURES

- I Up to 10.5 Gb/s Bi-directional Data Link
- I Complaint to SFP+ MSA
- I Compliant with 10GBASE-SR
- I Compliant with 10GBASE- SW
- I Link Distance at 10.3 Gbd
 - 300 m links with OM3 MMF Cables
 - 82 m links with OM2 MMF Cables
 - 33 m links with OM1 MMF Cables
- I **SFF-8472 Digital Diagnostic Function**
- I AC/AC Coupling according to MSA
- I Single +3.3 V Power Supply
- I RoHS 6/6 Compliant
- I 0 to 70°C Operation: SPM-2100WG
- I -10 to 85°C Operation: SPM-2100BWG
- I -40 to 85°C Operation: SPM-2100AWG
- I Class 1 Laser International Safety Standard IEC 60825 Compliant

DESCRIPTION

The SPM-2100WG series multi-mode transceivers is SFP+ module for bi-directional serial optical data communications such as 10GBASE-SR and 10GBASE-SW. It is with the SFP+ 20-pin connector to allow hot plug capability. Digital diagnostic functions are available via an I²C. This module is designed for multi-mode fiber and operates at a nominal wavelength of 850 nm. The transmitter section uses a Vertical Cavity Surface Emitted Laser (VCSEL) and is a Class 1 laser compliant according to International Safety Standard IEC 60825. The receiver section uses an integrated GaAs detector preamplifier (IDP) mounted in an optical header and a limiting post-amplifier IC.

LASER SAFETY

This multi-mode transceiver is a Class 1 laser product. It complies with IEC 60825 and FDA 21 CFR 1040.10 and 1040.11. The transceiver must be operated within the specified temperature and voltage limits. The optical ports of the module shall be terminated with an optical connector or with a dust plug.

APPLICATIONS

- I 10G Ethernet at 10.3125Gbps

ORDER INFORMATION

P/No.	Bit Rate (Gb/s)	10GBASE	Distance (m)	Wavelength (nm)	Package	Temp. (°C)	RoHS Compliant
SPM-2100WG	10.3	SR / SW	300 / 82 / 33*	850 VCSEL	SFP+ with DMI	0 to 70	Yes
SPM-2100BWG	10.3	SR / SW	300 / 82 / 33*	850 VCSEL	SFP+ with DMI	-10 to 85	Yes
SPM-2100AWG	10.3	SR / SW	300 / 82 / 33*	850 VCSEL	SFP+ with DMI	-40 to 85	Yes

*: 300m for OM3 MMF, 82m for OM2 MMF, and 33 m for OM1 MMF.

Absolute Maximum Ratings					
Parameter	Symbol	Min	Max	Units	Notes
Storage Temperature	Tstg	-40	85	°C	
Operating Case Temperature	Topr	0	70	°C	SPM-2100WG
		-10	85		SPM-2100BWG
		-40	85		SPM-2100AWG
Operating Relative Humidity	RH	5	95	%	Non condensing
Power Supply Voltage	Vcc	0	4	V	

Recommended Operating Conditions					
Parameter	Symbol	Min	Typ	Max	Units / Notes
Power Supply Voltage	Vcc	3.14	3.3	3.46	V
Operating Case Temperature	Topr	0		70	°C
		-10		85	
		-40		85	
Power Supply Current	I _{CC(TX+RX)}		135	180	mA
Data Rate			10.3125	10.5	Gb/s

Transmitter Optical Specifications (0°C < T_{opr} < 70°C, 3.13V < V_{cc} < 3.47V)						
Parameter	Symbol	Min	Typ	Max	Units	Notes
Average Launch Power	P _{O, Avg}	-7.3		-1.0	dBm	1
Optical Modulation Amplitude	P _{O, OMA}	*			mW	2
Output Center Wavelength	λ _c	840	850	860	nm	
Output Spectrum Width	σ _λ			0.45	nm	RMS (σ)
Transmitter Dispersion Penalty	TDP			3.9	dB	
Relative Intensity Noise	RIN			-128	dB/Hz	12 dB reflection

- Output power is power coupled into a 50/125 μm multi-mode fiber.
- *:Trade-offs between center wavelength, spectral width, and minimum OMA based on IEEE 802.3ae Table 52-8 are used.

Receiver Optical Specifications (0°C < T_{opr} < 70°C, 3.13V < V_{cc} < 3.47V)						
Parameter	Symbol	Min	Typ	Max	Units	Notes
Receiver Sensitivity	Sens1			-9.9	dBm	3
Stress Sensitivity (OMA)	Sens2		---	180	μWp-p	3, ISI=3.5 dB
Receiver Overload	P _{MAX}	-1	---		dBm	
LOS -- Deasserted	LOS _D	---	---	-14	dBm	Transition: low to high
LOS -- Asserted	LOS _A	-25	---	---	dBm	Transition: high to low
Wavelength of Operation	λ _c	840	850	860	nm	
Optical Return Loss	ORL			-12	dB	

- Measured with worst ER; BER < 10⁻¹² and PRBS 2³¹-1.

Electrical Characteristics						
Parameter	Symbol	Min	Typ	Max	Units	Notes
High-Speed Signal (CML) Interface Specification						
Input Data Rate			10.3125	10.5	Gb/s	
Differential Input Impedance	R _{in}		100		Ω	
Differential Data Input Amplitude		150		1200	mV _{pp}	Internally AC coupled
Output Data Rate			10.3125	10.5	Gb/s	
Differential Output Impedance	R _{out}		100		Ω	
Differential Data Output Amplitude		350	600	700	mV _{pp}	Internally AC coupled
Low-Speed Signal (LVTTTL) Interface Specification						
Input High Voltage		2.0		V _{cc} +0.3	V	
Input Low Voltage		GND		0.8	V	
Output High Voltage		2.4		V _{cc}	V	
Output Low Voltage		GND		0.5	V	

LINK LENGTH

Data Rate / Standard	Fiber Type	Model Bandwidth @ 850nm (MHz-km)	Distance Range (m)
10.3 GBd	62.5/125 μm MMF (OM1)	200	2 to 33
	50 / 125 μm MMF (OM2)	500	2 to 82
	50 / 125 μm MMF	900	2 to 150
	50 / 125 μm MMF	1500	2 to 240
	50 / 125 μm MMF (OM3)	2000	2 to 300

CONNECTION DIAGRAM

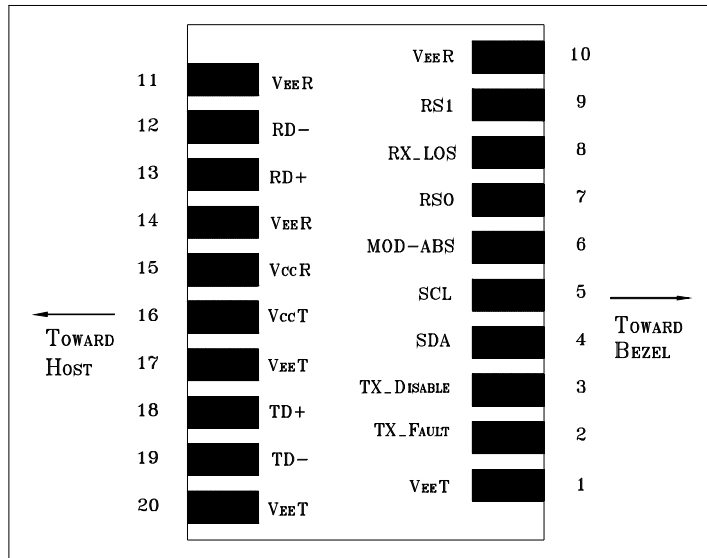

PIN	Signal Name	Description	PIN	Signal Name	Description
1	V _{EE} T	Transmitter Signal Ground	11	V _{EE} R	Receiver Signal Ground
2	TX_Fault	Transmitter Fault Indication. Logic "1" Output = Laser Fault. Logic "0" Output = Normal Operation	12	RD-	Inverse Receiver Data Out
3	TX_Disable	Logic "1" Input (or no connection) = TX off, Logic "0" = TX on.	13	RD+	Receiver Data Out
4	SDA	Modulation Definition 2 – Two wires serial ID Interface	14	V _{EE} R	Receiver Signal Ground
5	SDL	Modulation Definition 1 – Two wires serial ID Interface	15	V _{CC} R	Receiver Power – 3.3V±5%
6	MOD-ABS	Modulation Absent, connected to V _{EE} T or V _{EE} R in the module.	16	V _{CC} T	Transmitter Power – 3.3V±5%
7	RS0	RX Rate Select (LVTTTL). This pin has an internal 30k pull-down to ground. A signal on this pin will not affect module performance.	17	V _{EE} T	Transmitter Signal Ground
8	RX_LOS	Loss of Signal Out (OC).	18	TD+	Transmitter Data In
9	RS1	TX Rate Select (LVTTTL). This pin has an internal 30k pull-down to ground. A signal on this pin will not affect module performance.	19	TD-	Inverse Transmitter Data In
10	V _{EE} R	Receiver Signal Ground	20	V _{EE} T	Transmitter Signal Ground

MODULE DEFINITION

Module Definition	PIN 4	PIN 5	PIN 6	Interpretation by Host
4	SDA	SCL	MOD-ABS	Serial module definition protocol

Module Definition 4 specifies a serial definition protocol. For this definition, upon power up, SDA and SDL appear as no connector (NC) and MOD-ABS is TTL LOW. When the host system detects this condition, it activates the serial protocol. The protocol uses the 2-wire serial CMOS E²PROM protocol of the ATMEL AT24C01A/02/04 family of components.

RECOMMENDED CIRCUIT SCHEMATIC

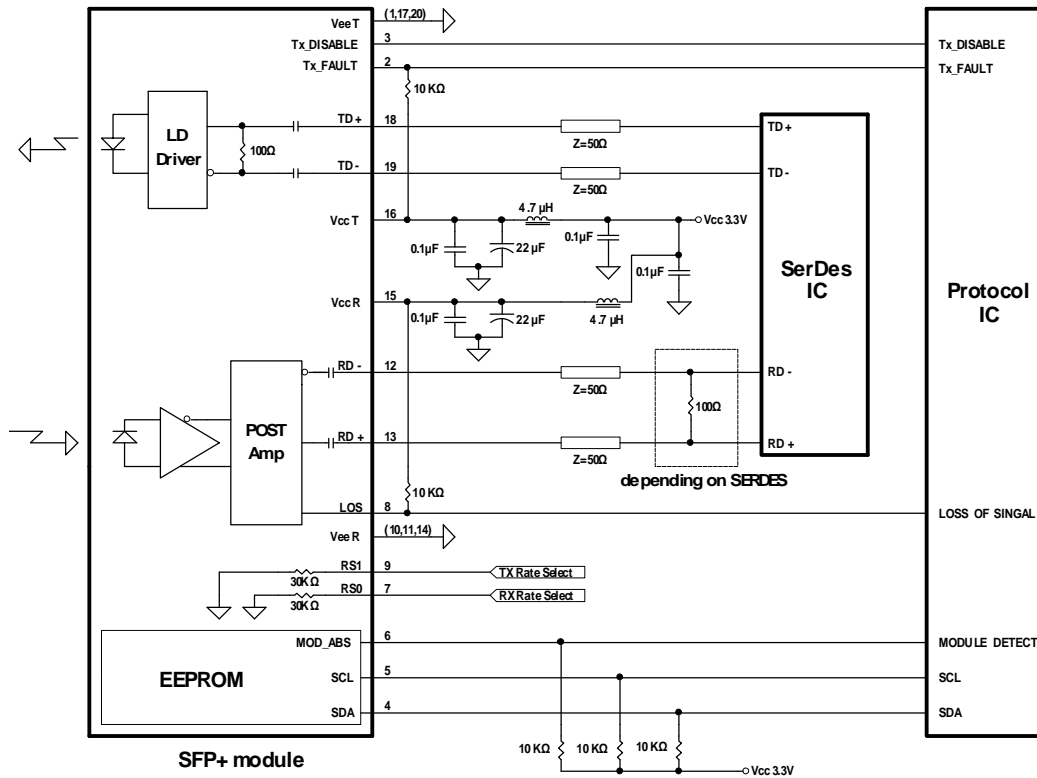

PACKAGE DIAGRAM

Units in mm

Top View

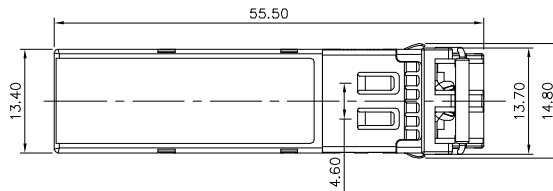

Front View

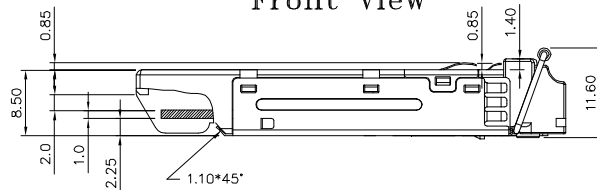

LATCH COLOR
BLACK:MM

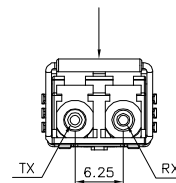

Side View

Bottom View

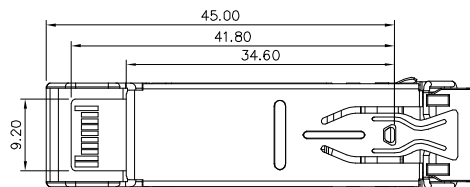

Note: Specifications subject to change without notice.

REVISION HISTORY

Version	Subject	Release Date
1.0	Initial datasheet	2007/8/1
2.0	Add SPM-2100BWG for -10 to 85°C operating	2009/3/1
3.0	Add SPM-2100AWG for -40 to 85°C operating	2009/10/1