

NU-73D74D-PG / NU-73D74D-RG

(RoHS Compliant)

3.3V, 1.25 Gbps 1310 nm Burst-Mode TX / 1.25 Gbps 1490 nm Continuous RX

2X5 SFF Package, GE-PON 1000BASE-PX10-U ONU Transceiver

FEATURES

- | Optical Network Unit (ONU) for 1000BASE-PX10-U
- | Single-SM Fiber Bi-directional WDM Transceiver with **3W-TRX™** for the Video-Overlay Application
- | 1.25 Gbps / 1310 nm Burst-Mode Transmitter
- | 1.25 Gbps / 1490 nm Continuous-Mode Receiver with 2R Output with rejection of 1.55 um video signal
- | 0 to 70°C Operating Temperature
- | 2x5 Package with Pigtail : NU-73D74D-PG
- | 2x5 Package with Receptacle : NU-73D74D-RG
- | 0 to 70°C Operating
- | Single +3.3 V Power Supply
- | RoHS Compliant
- | LVPECL Differential Inputs and Outputs
- | LVTTTL TX Laser DC Bias Control
- | High Speed Laser DC-Bias Turn-on and Turn-off
- | LVTTTL RX Signal Detect Output
- | Wave Solderable and Aqueous Washable
- | Class 1 Laser International Safety Standard IEC-60825 Compliant

DESCRIPTION

NU-73D74D is a transceiver for the optical network unit (ONU) of GE-PON with 1.25Gbps in downstream and 1.25 Gbps in upstream. The NU-73D74D is high performance module for single fiber communications by using 1310 nm burst-mode transmitter and 1490 nm continuous-mode receiver. The receiver section is equipped with **3W-TRX™** to reject incoming high power 1550 nm video signal, where the rejection ratio is over 40 dB. The transmitter section uses a multiple quantum well 1310 nm laser and is a class 1 laser compliant according to International Safety Standard IEC-60825. The receiver section uses an integrated 1490 nm detector preamplifier (IDP) mounted in an optical header and a limiting post-amplifier IC. LVPECL interface is used for differential inputs and outputs. A LVTTTL logic interface simplifies interface to external circuitry.

LASER SAFETY

This single mode transceiver is a Class 1 laser product. It complies with IEC-60825 and FDA 21 CFR 1040.10 and 1040.11. The transceiver must be operated within the specified temperature and voltage limits. The optical ports of the module shall be terminated with an optical connector or with a dust plug.

APPLICATIONS

- | Broadband GE-PON System

ORDER INFORMATION

P/No.	IEEE 802.3ah	TX				RX				Temp. (°C)	Package	RoHS Compliant
		Type	Speed (Gb/s)	λ (nm)	Power (dBm)	Type	Speed (Gb/s)	λ (nm)	Sens. (dBm)			
NU-73D74D-PG*	PX10-U	BM	1.25	1310	4 / -1	CNT	1.25	1490	-3 / -26	0 to 70	2X5 SFF Pig.	Yes
NU-73D74D-RG*	PX10-U	BM	1.25	1310	4 / -1	CNT	1.25	1490	-3 / -26	0 to 70	2X5 SFF Rec.	Yes

NOTE: 1. XX-XXXXXXX-PG, SC/PC pigtail with fiber length 50 cm; XX-XXXXXXX-RG, SC/PC receptacle.

2. BM: Burst Mode; CNT: Continuous Mode; SFF: Small Form Factor Package.

3. * is **3W-TRX™** ONU transceiver for Video-overlay PON applications.

4. **3W-TRX™** is trade-mark co-owned by Optoway Technology Inc. and Zenko Technologies Inc.

Absolute Maximum Ratings					
Parameter	Symbol	Min.	Max.	Unit	Notes
Power Supply Voltage	V _{cc}	0	4	V	
Input Voltage		GND	V _{cc}	V	
Output Current	I _{out}	0	30	mA	
Operating Temperature	T _{opr}	0	70	°C	With air flow 1m/sec
Storage Temperature	T _{stg}	-40	85	°C	
Soldering Temperature			260	°C	10 seconds on leads only
Bending Radius of Fiber		30		mm	For pigtail product

Stress in excess of the maximum absolute ratings can cause permanent damage to the module.

Recommended Operating Conditions					
Parameter	Symbol	Min.	Max.	Unit	Notes
Power Supply Voltage	V _{cc}	3.13	3.47	V	3.3 V +/- 5 %
Power Supply Current	I _{cc, TX+RX}		280	mA	
Operating Temperature	T _{opr}	0	70	°C	With air flow 1m/sec

Transmitter Specifications (0°C < T _{opr} < 70°C, 3.13V < V _{cc} < 3.47V)						
Parameter	Symbol	Min.	Typ.	Max.	Units	Notes
Optical						
Optical Transmit Power	P _o	-1		4	dBm	1
Output Center Wavelength	λ	1260	1310	1360	nm	
Output Spectrum Width	Δ λ _{RMS}	Meets for IEEE 802.3ah PX10-U transmitter spectral limits (Maximum allowed RMS spectral width)				
Extinction Ratio	E _R	9			dB	
Transmitter Reflection				-12	dB	
Background Light	BDL			-45	dBm	When BEN-pin is low.
Data Rate			1.25		Gb/s	
Optical Rise Time	t _r			0.26	ns	20% to 80% Values
Optical Fall Time	t _f			0.26	ns	20% to 80% Values
Relative Intensity Noise	RIN			-115	dB/Hz	
Total Jitter	T _j			0.128	ns	
Electrical						
Data Input Current – Low		-350			μA	
Data Input Current – High				350	μA	
Differential Input Voltage	V _{IH} - V _{IL}	300		1600	mV	
Data Input Voltage – Low	V _{IL} - V _{CC}	-2.0		-1.58	V	2
Data Input Voltage -- High	V _{IH} - V _{CC}	-1.1		-0.74	V	2
DC-Bias Disable Input Voltage -- Low	V _{TDIS,L}	0		0.8	V	Laser DC-bias Disabled
DC-Bias Enable Input Voltage -- High	V _{TDIS,H}	V _{cc} - 1.3		V _{cc}	V	Laser DC-bias Enabled
TX DC-Bias Shut-off time	t _{dc,off}			20	ns	
TX DC-Bias Turn-on time	t _{dc,on}			20	ns	
TX Shut down time	T _{sdwn}		30		μs	

1. Output power is power coupled into a 9/125 μm single mode fiber.
2. These inputs are compatible with 10K, 10KH and 100K ECL and LVPECL inputs.

Receiver Characteristics (0°C < Topr < 70°C, 3.13V < Vcc < 3.47V)

Parameter	Symbol	Min.	Typ.	Max.	Units	Notes
Optical						
Sensitivity	Sen			-26	dBm	3
Saturation Optical Power	Sat	-3			dBm	3
Wavelength of Operation		1480		1500	nm	4
Rejection of 1550 nm Signal		40			dB	
Signal Detect Assert Level	Pa			-26	dBm	
Signal Detect Deassert Level	Pd	-45			dBm	
Signal Detect Hysteresis		1.0			dB	
Data Rate			1.25		Gb/s	
Optical Return Loss		14			dB	
Electrical						
Power Supply Current	Icc		100	130	mA	
Data Output Voltage – Low	V _{OL} - V _{CC}	-2.0		-1.58	V	5
Data Output Voltage – High	V _{OH} - V _{CC}	-1.1		-0.74	V	5
SD Output Voltage -- Low	V _{OL} - V _{CC}			0.8	V	
SD Output Voltage -- High	V _{OH} - V _{CC}	2.0			V	
Signal Detect Assert Time	AS _{MAX}			100	μs	OFF to ON
Signal Detect Deassert Time	ANS _{MAX}			300	μs	ON to OFF

- Sensitivity and saturation levels at BER 1E-12 @ 2⁷-1 PRBS @ER=9.
- At least 30 dB optical isolation for the wavelength 1260 to 1360 nm.
- These inputs are compatible with 10K, 10KH and 100K ECL and LVPECL outputs.

CONNECTION DIAGRAM

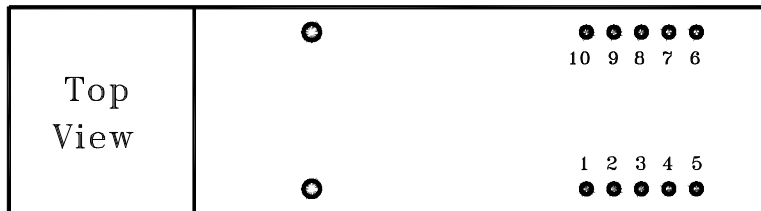

PIN	Symbol	I/O	Notes
1	RX-VEE	I	Directly connect this pin to the receiver ground plane
2	RX-VCC	I	+3.3V dc power for the receiver section
3	SD	O	Active high on this indicates presence of received optical signal (LVTTTL)
4	RD-	O	Receiver Dataout AC coupled.
5	RD+	O	Receiver Dataout. AC coupled.
6	TX-VCC	I	+3.3V dc power for the transmitter section
7	TX-VEE	I	Directly connect this plan to the transmitter ground plane
8	BEN	I	TX Burst enable Control. When this pin is "Hi (LVTTTL/LVCMOS)", TX burst is enabled. When this pin is "Lo (LVTTTL/LVCMOS)", TX burst is disabled. This pin is internally pulled to "Hi".
9	TD+	I	Transmitter Data In. DC coupled.
10	TD-	I	Transmitter Data Bar In. DC coupled.
MS	MS		Mounting Studs. Connect to Chassis Ground

RECOMMENDED CIRCUIT SCHEMATIC

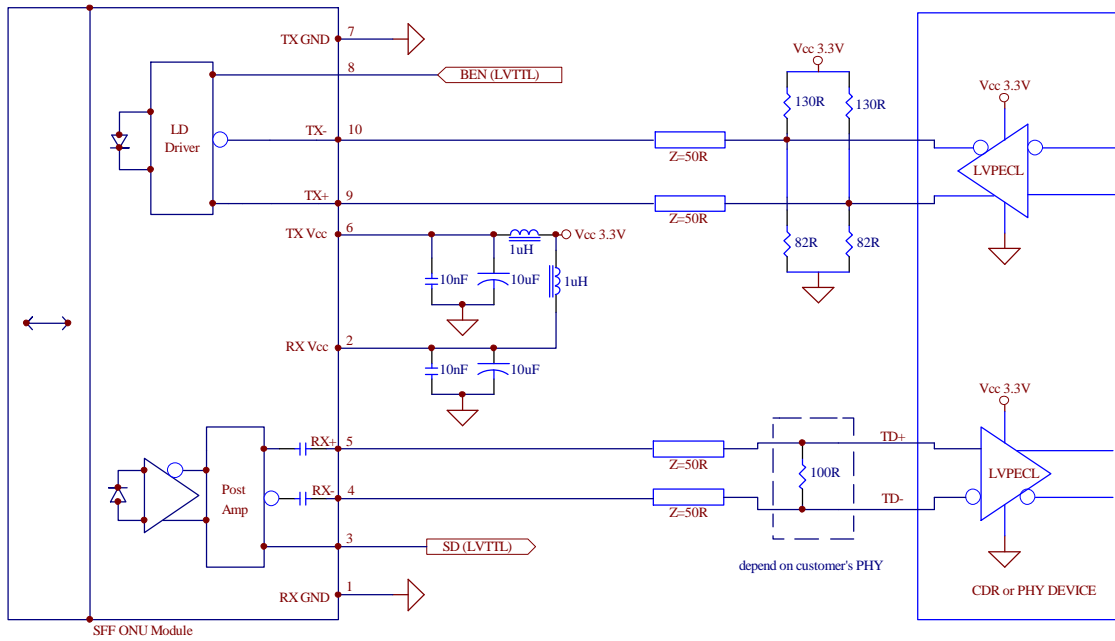

TRANSMITTER OPTICAL OUTPUT

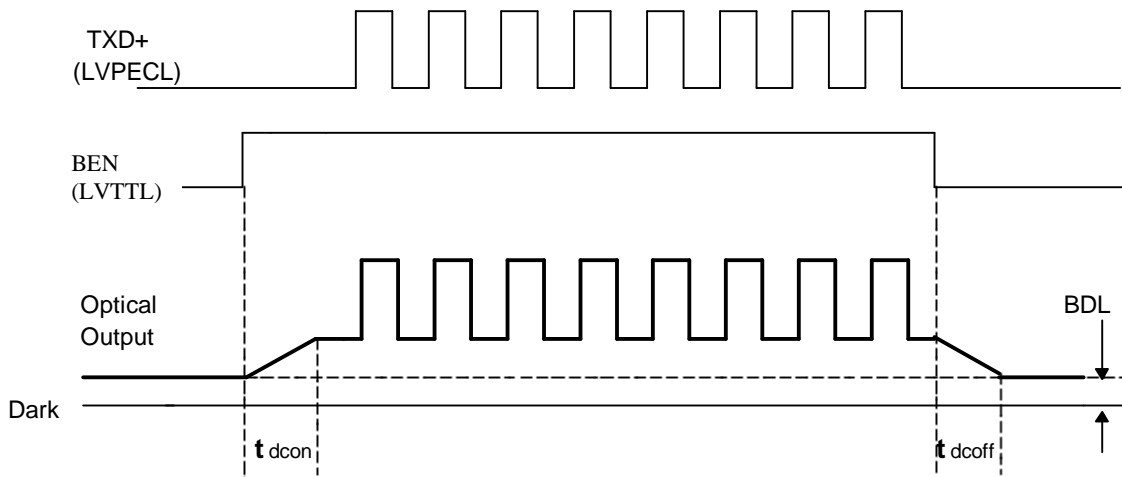

PACKAGE DIAGRAM

Units in mm

1) Pigtail

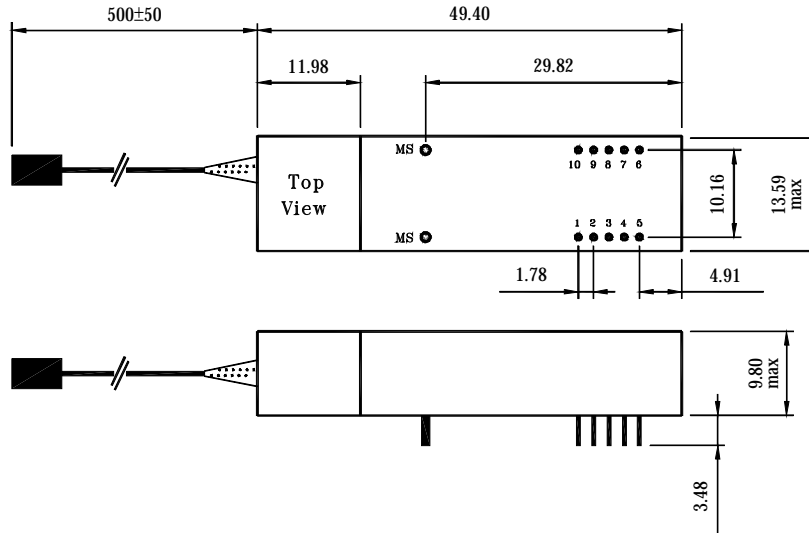

2) SC Receptacle

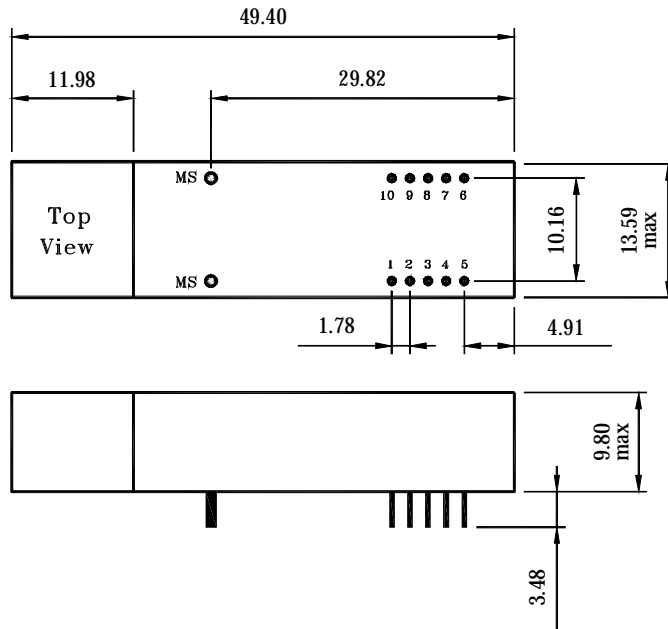

Note: Specifications subject to change without notice.