

**NU-73B94B-PG / NU-73B94B-P-AG**

**(RoHS Compliant)**

**3.3V, 1.244 Gbps 1310 nm Burst-Mode TX / 2.488 Gbps 1490 nm Continuous RX  
2X5 SFF Package, ITU-T G.984.2 Class B+ G-PON ONU Transceiver**

**FEATURES**

- | Class B+ Optical Network Unit (ONU) for ITU-T G.984.2 Gigabit-capable PON
- | Single-SM Fiber Bi-directional WDM Transceiver
- | 1.244 Gbps / 1310 nm Burst-Mode Transmitter
- | 2.488 Gbps / 1490 nm Continuous-Mode Receiver with 2R Output
- | 2x5 Package with SC/PC Pigtail
- | 0 to 70°C Operating: NU-73B94B-PG
- | -30 to 85°C Operating: NU-73B94B-P-AG
- | Single +3.3 V Power Supply
- | RoHS Compliant
- | DC Coupled Input Interface
- | AC Coupled Output Interface
- | LVTTL TX Burst Enable Control
- | LVTTL RX Signal Detect Output
- | Wave Solderable and Aqueous Washable
- | Class 1 Laser International Safety Standard IEC 60825 Compliant

**DESCRIPTION**

NU-73B94B series is a transceiver for the optical network unit (ONU) of G-PON with 2.488 Gbps in downstream and 1.244 Gbps in upstream. The NU-73B94B is high performance module for single fiber communications by using 1310 nm burst-mode transmitter and 1490 nm continuous-mode receiver. The transmitter section uses a multiple quantum well 1310 nm laser and is a class 1 laser compliant according to International Safety Standard IEC 60825. The receiver section uses an integrated 1490 nm detector preamplifier (IDP) mounted in an optical header and a limiting post-amplifier IC. LVPECL interface is used for differential inputs and outputs. A LVTTTL logic interface simplifies interface to external circuitry.

**LASER SAFETY**

This single mode transceiver is a Class 1 laser product. It complies with IEC 60825 and FDA 21 CFR 1040.10 and 1040.11. The transceiver must be operated within the specified temperature and voltage limits. The optical ports of the module shall be terminated with an optical connector or with a dust plug.

**APPLICATIONS**

- | Broadband G-PON System

**ORDER INFORMATION**

P/No	Class	TX				RX				Temp (°C)	Package	RoHS Complaint
		Type	Speed (Gb/s)	λ (nm)	Power (dBm)	Type	Speed (Gb/s)	λ (nm)	Sens. (dBm)			
NU-73B94B-PG	B+	BM	1.244	1310 DFB	5 / 0.5	CNT	2.488	1490	-8 / -27	0 / 70	SFF 2X5 Pig.	Yes
<b>NU-73B94B-P-AG</b>	B+	BM	1.244	1310 DFB	5 / 0.5	CNT	2.488	1490	-8 / -27	<b>-30 / 85</b>	SFF 2X5 Pig.	Yes

NOTE: 1. NU-XXXXXX-PG, SC/PC pigtail with fiber length 50 cm. NU-XXXXXX-APG, SC/APC pigtail with fiber length 50 cm.  
2. BM: Burst Mode; CNT: Continuous Mode; SFF: Small Form Factor Package.

Absolute Maximum Ratings					
Parameter	Symbol	Min.	Max.	Unit	Notes
Power Supply Voltage	V <sub>cc</sub>	0	4	V	
Input Voltage		GND	V <sub>cc</sub>	V	
Output Current	I <sub>out</sub>	0	30	mA	
Operating Case Temperature	T <sub>opr</sub>	0	70	°C	NU-73B94B-PG
		-30	85	°C	NU-73B94B-P-AG
Storage Temperature	T <sub>stg</sub>	-40	85	°C	
Soldering Temperature			260	°C	10 seconds on leads only
Bending Radius of Fiber		30		mm	For pigtail product

Stress in excess of the maximum absolute ratings can cause permanent damage to the module.

Recommended Operating Conditions					
Parameter	Symbol	Min.	Max.	Unit	Notes
Power Supply Voltage	V <sub>cc</sub>	3.13	3.47	V	3.3 V +/- 5 %
Operating Case Temperature	T <sub>opr</sub>	0	70	°C	NU-73B94B-PG
		-30	85	°C	NU-73B94B-P-AG
Power Supply Current	I <sub>CC(TX+RX)</sub>		300	mA	

Transmitter Specifications (0°C < T <sub>opr</sub> < 70°C, 3.13V < V <sub>cc</sub> < 3.47V )						
Parameter	Symbol	Min.	Typ.	Max.	Units	Notes
<b>Optical</b>						
Optical Transmit Power	P <sub>o</sub>	0.5		5	dBm	1
Output Center Wavelength	λ	1261	1310	1360	nm	
Output Spectrum Width	Δ λ			1	nm	-20 dB width
Side Mode Suppression Ratio	SMSR	30			dB	
Data Rate			1.244		Gb/s	
Optical rise and Fall Time	T <sub>r</sub> / T <sub>f</sub>			0.26	ns	80%/20%
Extinction Ratio	E <sub>R</sub>	10			dB	
Background Light	BDL			-45	dBm	BEN disable
Relative Intensity Noise	RIN			-120	dB/Hz	
<b>Electrical</b>						
Data Input Current – Low		-350			μA	
Data Input Current – High				350	μA	
Data Input Voltage – Low	V <sub>IL</sub>	V <sub>cc</sub> - 1.935		V <sub>cc</sub> - 1.56	V	
Data Input Voltage -- High	V <sub>IH</sub>	V <sub>cc</sub> - 1.135		V <sub>cc</sub> - 0.76	V	
DC-Bias Disable Input Voltage -- Low	V <sub>TDISL</sub>	0		0.8	V	TX BEN OFF.
DC-Bias Enable Input Voltage -- High	V <sub>TDISH</sub>	V <sub>cc</sub> - 1.3		V <sub>cc</sub>	V	TX BEN ON
TX Burst Turn-on Time (BEN pin)	t <sub>dc,off</sub>			12.86	ns	16 bit data at 1.244 Gbps
TX Burst Turn-off Time (BEN pin)	t <sub>dc,on</sub>			12.86	ns	16 bit data at 1.244 Gbps

1. Output power is power coupled into a 9/125 μm single mode fiber.

Receiver Characteristics (0°C < Topr < 70°C, 3.13V < Vcc < 3.47V )

Parameter	Symbol	Min.	Typ.	Max.	Units	Notes
<b>Optical</b>						
Sensitivity	Sen	-8		-27	dBm	2
Wavelength of Operation		1480		1500	nm	3
Signal Detect Assert Level	Pa			-27	dBm	
Signal Detect Deassert Level	Pd	-45			dBm	
Signal Detect Hysteresis		1.5	2		dB	
Data Rate			2.488		Gb/s	
Optical Return Loss		20			dB	
<b>Electrical</b>						
Differential Data Output Voltage		500		1200	mVp-p	AC coupled Output
SD Output Voltage -- Low	V <sub>OL</sub>			0.8	V	LVTTL Output
SD Output Voltage -- High	V <sub>OH</sub>	2.0		V <sub>cc</sub>	V	
Signal Detect Assert Time	AS <sub>MAX</sub>	2		100	μs	OFF to ON
Signal Detect Deassert Time	ANS <sub>MAX</sub>	2		100	μs	ON to OFF

2. Sensitivity and saturation levels at BER 1E-10 for a 2<sup>23</sup>-1 PRBS @ ER=10.

3. At least 30 dB optical isolation for the wavelength 1260 to 1360 nm.

## CONNECTION DIAGRAM

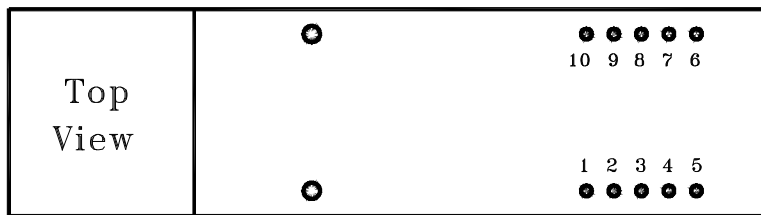

PIN	Symbol	I/O	Notes
1	RX-VEE	I	Directly connect this pin to the receiver ground plane
2	RX-VCC	I	+3.3V dc power for the receiver section
3	SD	O	Active high on this indicates presence of received optical signal (LVTTL)
4	RD-	O	Receiver Dataout AC coupled.
5	RD+	O	Receiver Dataout. AC coupled.
6	TX-VCC	I	+3.3V dc power for the transmitter section
7	TX-VEE	I	Directly connect this plan to the transmitter ground plane
8	BEN	I	TX Burst enable Control. When this pin is "Hi (LVTTL/LVCMOS)", TX burst is enabled. When this pin is "Lo (LVTTL/LVCMOS)", TX burst is disabled. This pin is internally pulled to "Hi".
9	TD+	I	Transmitter Data In. DC coupled.
10	TD-	I	Transmitter Data Bar In. DC coupled.
MS	MS		Mounting Studs. Connect to Chassis Ground

## RECOMMENDED CIRCUIT SCHEMATIC

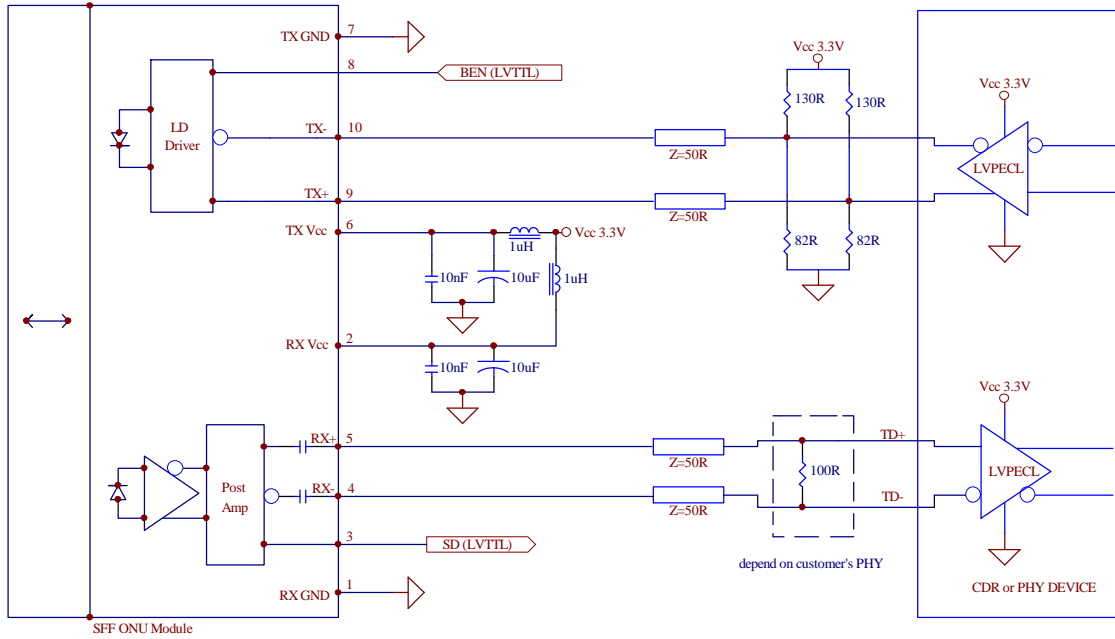

## TRANSMITTER OPTICAL OUTPUT

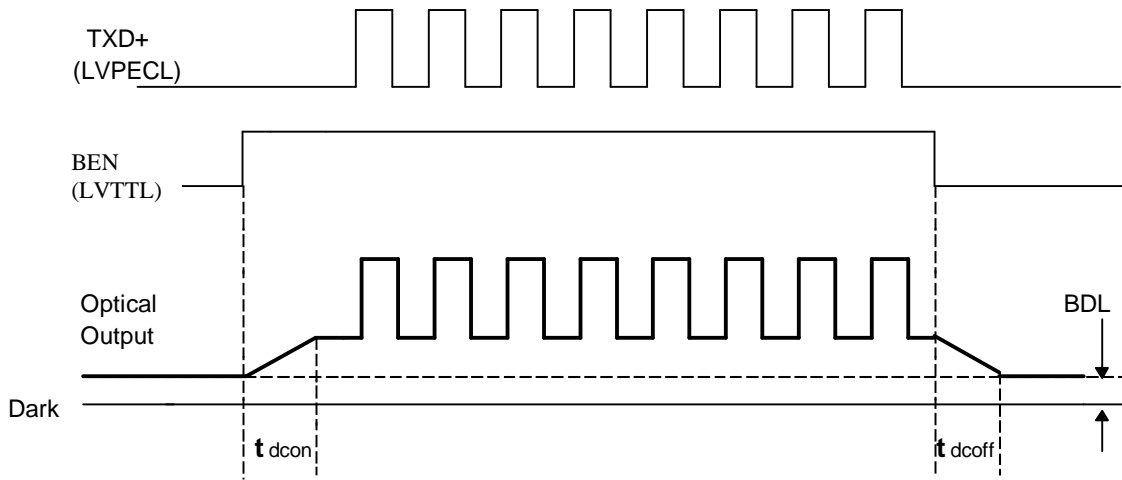

PACKAGE DIAGRAM

Units in mm

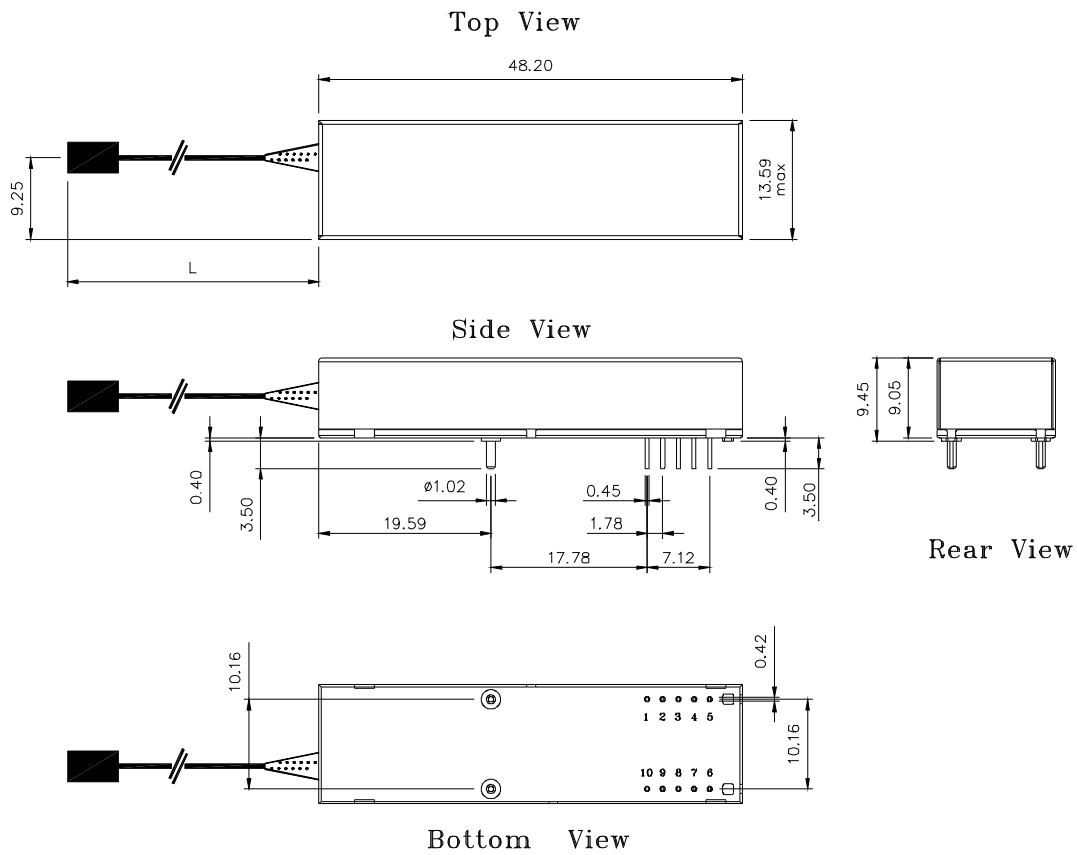

**Note:** Specifications subject to change without notice. L= 50 cm +/- 5 cm and SC/PC connector is standard. If non-standard fiber pigtail is required, please contact [sales@optoway.com.tw](mailto:sales@optoway.com.tw).

RECOMMENDED CIRCUIT BOARD LAYOUT

Top View

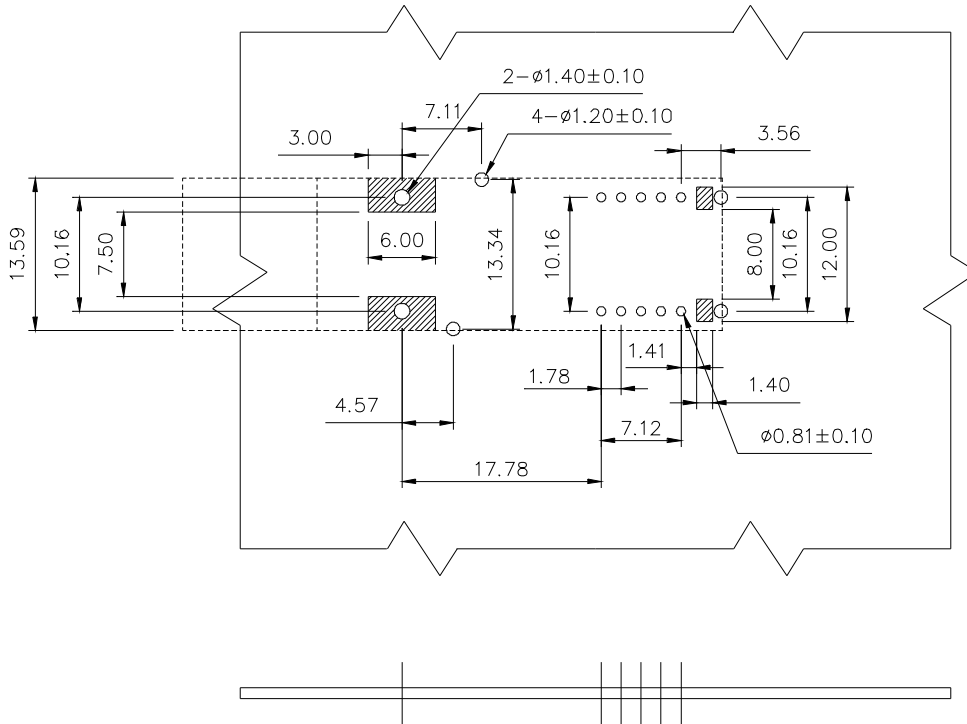

Notes:

1. This figure describes the recommended circuit board layout for the SFF ONU Transceiver.
2. The hatched areas are keep-out areas reserved for housing standoff. No metal traces or ground connection in keep-out area.
3. The mounting studs should be solder to chassis ground for mechanical integrity.