3.3V / 1.55 μ m / 1.25 Gbps InGaAs PIN-TIA Receiver **PT-57130 Series**

FEATURES

- ✧ InGaAs/InP PIN Photodiode with AGC transimpedance amplifier
- ✧ Differential ended output
- ✧ 1.55 μ m high sensitivity, 1.3 μ m high rejection
- ✧ Single +3.3V operation
- ✧ Speed Up to 1.25 Gbps
- ✧ - 40 ~ +85 °C operation temperature

DESCRIPTION

PT-57130 series is designed as optical receivers with transimpedance amplifier. Their wide dynamic ranges, differential outputs are suited for Datacom and Telecom applications , especially Gigabit Ethernet, Fiber Channel, and SONET OC-24/SDH STM-8.

AC / ELECTRICAL AND OPTICAL CHARACTERISTICS (T _C =25°C)						
Symbol	Parameter	Test Conditions	Min.	Typ.	Max.	Unit
	Detection Range		1480	1550	1600	nm*
	Active Area			75		μ m
G	Differential Gain	AC coupled, load=50 Ω	6	8	10	V/mW
BW	Bandwidth	-3 dB point	850			MHz
Psat	Saturation Power	λ =1300nm	-3			dBm
Sens	Sensitivity	BER=10 ⁻¹² @ 1.25Gb/s	-	-	-21	dBm
Rout	Output Resistance		-	50	65	ohm
	Speed			1250		Mbps

Note: *: At least 30 dB isolation for wavelength 1260 nm to 1360 nm

DC / ELECTRICAL CHARACTERISTICS (T _C =25°C)					
Symbol	Parameter	Min.	Typ.	Max.	Unit
V _{CC}	Power Supply	3.1	3.3	3.5	V
I _{CC}	Supply Current (no load)	-	-	30	mA

ABSOLUTE MAXIMUM RATING (T _C =25 °C)			
Symbol	Parameter	Value	Unit
V	Voltage	4.5	V
T _{opr}	Operating Temperature	-40~+85	°C
T _{stg}	Storage Temperature	-40~+85	°C

MECHANICAL DIMENSION (mm) and PIN ASSIGNMENT

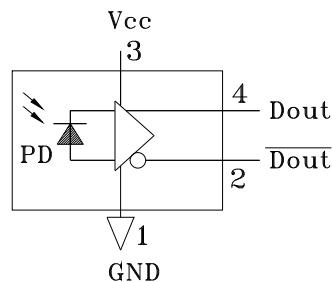
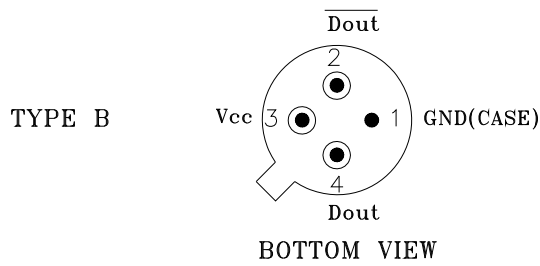
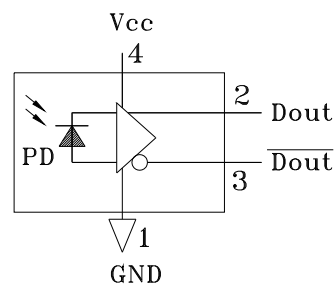
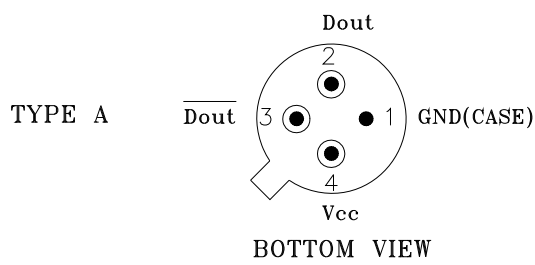
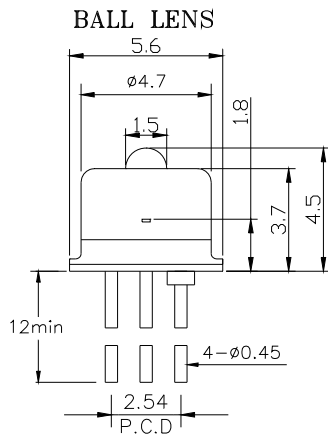

Note: Specifications subject to change without notice.

ORDER INFORMATION

Part No.: P T - 5 7 1 3 0 □

Code	Wavelength
Blank	1310/1550 nm
3	1310 nm
5	1550 nm

Code	PIN Assignment
Blank	Type A
B	Type B

Revision History

Version	Subject	Release Date
1.0	Initial datasheet	2003/2/1
